

# **PHILIPPINE BIDDING DOCUMENTS**

(As Harmonized with Development Partners)

Government of the Republic of the Philippines

## **SUPPLY AND DOOR-TO-DOOR DELIVERY OF SCHOOL FURNITURE TO VARIOUS SCHOOLS IN DEPED CORDILLERA ADMINISTRATIVE REGION (DEPED-CAR) WITH 2 LOTS UNDER CY 2024 BEFF SCHOOL FURNITURE PROGRAM**

**DEPED-CAR RO – CB 2024-10-023**

**Sixth Edition  
July 2020**

# Table of Contents

<b>Glossary of Acronyms, Terms, and Abbreviations .....</b>	<b>3</b>
<b>Section I. Invitation to Bid.....</b>	<b>7</b>
<b>Section II. Instructions to Bidders.....</b>	<b>10</b>
1. Scope of Bid .....	11
2. Funding Information.....	11
3. Bidding Requirements .....	11
4. Corrupt, Fraudulent, Collusive, and Coercive Practices .....	12
5. Eligible Bidders.....	12
6. Origin of Goods .....	12
7. Subcontracts .....	12
8. Pre-Bid Conference .....	12
9. Clarification and Amendment of Bidding Documents .....	13
10. Documents comprising the Bid: Eligibility and Technical Components .....	13
11. Documents comprising the Bid: Financial Component .....	13
12. Bid Prices .....	14
13. Bid and Payment Currencies .....	14
14. Bid Security .....	14
15. Sealing and Marking of Bids .....	15
16. Deadline for Submission of Bids .....	15
17. Opening and Preliminary Examination of Bids .....	15
18. Domestic Preference .....	15
19. Detailed Evaluation and Comparison of Bids .....	16
20. Post-Qualification .....	16
21. Signing of the Contract .....	16
<b>Section III. Bid Data Sheet .....</b>	<b>17</b>
<b>Section IV. General Conditions of Contract.....</b>	<b>21</b>
1. Scope of Contract .....	22
2. Advance Payment and Terms of Payment .....	22
3. Performance Security .....	22
4. Inspection and Tests .....	22
5. Warranty .....	23
6. Liability of the Supplier .....	24
<b>Section V. Special Conditions of Contract .....</b>	<b>23</b>
<b>Section VI. Schedule of Requirements .....</b>	<b>29</b>
<b>Section VII. Technical Specifications .....</b>	<b>30</b>
<b>Section VIII. Checklist of Technical and Financial Documents .....</b>	<b>43</b>

# *Glossary of Acronyms, Terms, and Abbreviations*

**ABC** – Approved Budget for the Contract.

**BAC** – Bids and Awards Committee.

**Bid** – A signed offer or proposal to undertake a contract submitted by a bidder in response to and in consonance with the requirements of the bidding documents. Also referred to as *Proposal* and *Tender*. (2016 revised IRR, Section 5[c])

**Bidder** – Refers to a contractor, manufacturer, supplier, distributor and/or consultant who submits a bid in response to the requirements of the Bidding Documents. (2016 revised IRR, Section 5[d])

**Bidding Documents** – The documents issued by the Procuring Entity as the bases for bids, furnishing all information necessary for a prospective bidder to prepare a bid for the Goods, Infrastructure Projects, and/or Consulting Services required by the Procuring Entity. (2016 revised IRR, Section 5[e])

**BIR** – Bureau of Internal Revenue.

**BSP** – Bangko Sentral ng Pilipinas.

**Consulting Services** – Refer to services for Infrastructure Projects and other types of projects or activities of the GOP requiring adequate external technical and professional expertise that are beyond the capability and/or capacity of the GOP to undertake such as, but not limited to: (i) advisory and review services; (ii) pre-investment or feasibility studies; (iii) design; (iv) construction supervision; (v) management and related services; and (vi) other technical services or special studies. (2016 revised IRR, Section 5[i])

**CDA** - Cooperative Development Authority.

**Contract** – Refers to the agreement entered into between the Procuring Entity and the Supplier or Manufacturer or Distributor or Service Provider for procurement of Goods and Services; Contractor for Procurement of Infrastructure Projects; or Consultant or Consulting Firm for Procurement of Consulting Services; as the case may be, as recorded in the Contract Form signed by the parties, including all attachments and appendices thereto and all documents incorporated by reference therein.

**CIF** – Cost Insurance and Freight.

**CIP** – Carriage and Insurance Paid.

**CPI** – Consumer Price Index.

**DDP** – Refers to the quoted price of the Goods, which means “delivered duty paid.”

**DTI** – Department of Trade and Industry.

**EXW** – Ex works.

**FCA** – “Free Carrier” shipping point.

**FOB** – “Free on Board” shipping point.

**Foreign-funded Procurement or Foreign-Assisted Project**–Refers to procurement whose funding source is from a foreign government, foreign or international financing institution as specified in the Treaty or International or Executive Agreement. (2016 revised IRR, Section 5[b]).

**Framework Agreement** – Refers to a written agreement between a procuring entity and a supplier or service provider that identifies the terms and conditions, under which specific purchases, otherwise known as “Call-Offs,” are made for the duration of the agreement. It is in the nature of an option contract between the procuring entity and the bidder(s) granting the procuring entity the option to either place an order for any of the goods or services identified in the Framework Agreement List or not buy at all, within a minimum period of one (1) year to a maximum period of three (3) years. (GPPB Resolution No. 27-2019)

**GFI** – Government Financial Institution.

**GOCC** –Government-owned and/or –controlled corporation.

**Goods** – Refer to all items, supplies, materials and general support services, except Consulting Services and Infrastructure Projects, which may be needed in the transaction of public businesses or in the pursuit of any government undertaking, project or activity, whether in the nature of equipment, furniture, stationery, materials for construction, or personal property of any kind, including non-personal or contractual services such as the repair and maintenance of equipment and furniture, as well as trucking, hauling, janitorial, security, and related or analogous services, as well as procurement of materials and supplies provided by the Procuring Entity for such services. The term “related” or “analogous services” shall include, but is not limited to, lease or purchase of office space, media advertisements, health maintenance services, and other services essential to the operation of the Procuring Entity. (2016 revised IRR, Section 5[r])

**GOP** – Government of the Philippines.

**GPPB** –Government Procurement Policy Board.

**INCOTERMS** – International Commercial Terms.

**Infrastructure Projects** – Include the construction, improvement, rehabilitation, demolition, repair, restoration or maintenance of roads and bridges, railways, airports, seaports, communication facilities, civil works components of information technology projects, irrigation, flood control and drainage, water supply, sanitation, sewerage and solid waste management systems, shore protection, energy/power and electrification facilities, national

buildings, school buildings, hospital buildings, and other related construction projects of the government. Also referred to as *civil works or works*. (2016 revised IRR, Section 5[u])

**LGUs** – Local Government Units.

**NFCC** – Net Financial Contracting Capacity.

**NGA** – National Government Agency.

**PhilGEPS** - Philippine Government Electronic Procurement System.

**Procurement Project** – refers to a specific or identified procurement covering goods, infrastructure project or consulting services. A Procurement Project shall be described, detailed, and scheduled in the Project Procurement Management Plan prepared by the agency which shall be consolidated in the procuring entity's Annual Procurement Plan. (GPPB Circular No. 06-2019 dated 17 July 2019)

**PSA** – Philippine Statistics Authority.

**SEC** – Securities and Exchange Commission.

**SLCC** – Single Largest Completed Contract.

**Supplier** – refers to a citizen, or any corporate body or commercial company duly organized and registered under the laws where it is established, habitually established in business and engaged in the manufacture or sale of the merchandise or performance of the general services covered by his bid. (Item 3.8 of GPPB Resolution No. 13-2019, dated 23 May 2019). Supplier as used in these Bidding Documents may likewise refer to a distributor, manufacturer, contractor, or consultant.

**UN** – United Nations.

***Section I. Invitation to Bid***



**Republic of the Philippines  
Department of Education  
Cordillera Administrative Region  
Wangal, La Trinidad, Benguet**

---

**INVITATION TO BID  
FOR THE**

**SUPPLY AND DOOR-TO-DOOR DELIVERY OF SCHOOL FURNITURE TO  
VARIOUS SCHOOLS IN DEPED CORDILLERA ADMINISTRATIVE REGION  
(DEPED-CAR) WITH 2 LOTS UNDER CY 2024 BEFF SCHOOL FURNITURE  
PROGRAM**

1. The *Department of Education-Cordillera Administrative Region Regional Office (DepEd – CAR RO)*, through the *FY 2024 Government Appropriations Act (GAA) Fund* intends to apply the sum of:

Lot No.	Approved Budget to the Contract (Php)	Identification No.	Bidders
1	<b>90,149,600.00</b>	DepEd-CAR RO CB 2024-09-023 – Lot 1	Regular Suppliers
2	<b>16,029,894.00</b>	DepEd-CAR RO CB 2024-08-023 – Lot 2	Regular Cooperatives

being the ABC to payments under the contract for each lot. Bids received in excess of the ABC for each lot shall be automatically rejected at bid opening.

2. The **DepEd- CAR RO** through the Bids and Awards Committee (BAC) now invites bids for the above Procurement Project. ***Delivery of the Goods is required within one hundred fifty (150) calendar days after receipt of the Notice to Proceed.*** Bidders should have completed, within **five (5) years** from the date of submission and receipt of bids, a contract similar to the Project. The description of an eligible bidder is contained in the Bidding Documents, particularly, in Section II (Instructions to Bidders).
3. Bidding will be conducted through open competitive bidding procedures using a non-discretionary “*pass/fail*” criterion as specified in the 2016 revised Implementing Rules and Regulations (IRR) of Republic Act (RA) No. 9184.
- a. **Bidding is restricted to Filipino citizens/sole proprietorships, partnerships, or organizations with at least sixty percent (60%) interest or outstanding capital stock belonging to citizens of the Philippines, and to citizens or organizations of a country the laws or regulations of which grant similar rights or privileges to Filipino citizens, pursuant to RA No. 5183.**

4. Prospective Bidders may obtain further information from **DepEd-CAR Regional Office** and inspect the Bidding Documents at the address given below from **8:00am to 5:00pm** during working days.
5. **A complete set of Bidding Documents may be acquired by interested bidders starting on October 4, 2024 during office hours only** from the BAC Secretariat and upon payment of the applicable fee for the Bidding Documents, pursuant to the latest guidelines issued by the GPPB, in the amount of:

<i>Lot No.</i>	<i>Applicable fee for the Bidding Documents of each lot (Php)</i>
<i>1</i>	43,000.00
<i>2</i>	7,000.00
<i>Total</i>	50,000.00

It may also be downloaded free of charge from the website of the Philippine Government Electronic Procurement System (PhilGEPS) and the website of the Procuring Entity, provided that bidders shall pay the applicable fee for the Bidding Documents not later than the submission of their bids.

6. The DepEd-CAR Regional Office will hold a **Pre-Bidding Conference on October 11, 2024 at 9:00 AM at the OARD, DepEd-CAR RO, Wangal, La Trinidad, Benguet**, which shall be open to prospective bidders.
7. Bids must be duly received by the BAC Secretariat at the **Office of the Assistant Regional Director** of the DepEd-CAR RO, address below, **on or before 9:00 AM of October 24, 2024. Late bids shall not be accepted.**

**RONALD B. CASTILLO, CESO V**

*BAC Chairperson*

*Procurement Unit Office (BAC Secretariat Office)*

*DepED-CAR Regional Office*

*Wangal, La Trinidad, Benguet*

8. All Bids must be accompanied by a bid security in any of the acceptable forms and in the amount stated in **ITB** Clause 14.
9. **Bid opening shall be on October 24, 2024 at 9:01 AM at the OARD, DepEd-CAR, Wangal, La Trinidad, Benguet.** Bids will be opened in the presence of the bidders' representatives who choose to attend the activity.
10. The DepEd-CAR reserves the right to reject any and all bids, declare a failure of bidding, or not award the contract at any time prior to contract award in accordance with Sections 35.6 and 41 of the 2016



revised IRR of RA No. 9184, without thereby incurring any liability to the affected bidder or bidders.

11. For further information, please refer to:

*Atty. Edward C. Magalgalit, Jr./Randolph Flyn B. Daculog*  
*Chair, BAC Secretariat*  
*DepED-CAR Regional Office*  
*Wangal, La Trinidad, Benguet*  
*Email address: car.procurement@deped.gov.ph*  
*Tel. No. (074) 422-1318 Cp No. 09178218490/09207930509*  
*Website: www.depedcar.ph*

12. You may visit the following websites:

For downloading of Bidding Documents: *depedcar.ph*

**October 3, 2024**

  
**RONALD B. CASTILLO, CESO V**  
BAC Chairperson

## ***Section II. Instructions to Bidders***

## 1. Scope of Bid

The Procuring Entity, Department of Education- Cordillera Administrative Region wishes to receive Bids for the **Supply and Door-to-Door Delivery of School Furniture to Various Schools in DepEd Cordillera Administrative Region (DepEd-CAR) with 2 Lots under CY 2024 BEFF School Furniture Program** with the following Identification Numbers:

Lot No.	Identification No.
1	DepEd-CAR RO CB 2024-09-023 – Lot 1
2	DepEd-CAR RO CB 2024-08-023 – Lot 2

The Procurement Project (referred to herein as “Project”) is composed of *two (2) lots*, the details of which are described in Section VII (Technical Specifications).

## 2. Funding Information

2.1. The GOP through the source of funding as indicated below for FY 2024 GAA the amount of:

Lot No.	Approved Budget to the Contract (Php)	Bidders
1	<b>90,149,600.00</b>	Regular Suppliers
2	<b>16,029,894.00</b>	Regular Cooperatives

2.2. The source of funding is:

- a. **NGA, the General Appropriations Act or Special Appropriations**

## 3. Bidding Requirements

The Bidding for the Project shall be governed by all the provisions of RA No. 9184 and its 2016 revised IRR, including its Generic Procurement Manuals and associated policies, rules and regulations as the primary source thereof, while the herein clauses shall serve as the secondary source thereof.

Any amendments made to the IRR and other GPPB issuances shall be applicable only to the ongoing posting, advertisement, or **IB** by the BAC through the issuance of a supplemental or bid bulletin.

The Bidder, by the act of submitting its Bid, shall be deemed to have verified and accepted the general requirements of this Project, including other factors that may affect the cost, duration and execution or implementation of the contract, project, or work and examine all instructions, forms, terms, and project requirements in the Bidding Documents.

#### **4. Corrupt, Fraudulent, Collusive, and Coercive Practices**

The Procuring Entity, as well as the Bidders and Suppliers, shall observe the highest standard of ethics during the procurement and execution of the contract. They or through an agent shall not engage in corrupt, fraudulent, collusive, coercive, and obstructive practices defined under Annex “I” of the 2016 revised IRR of RA No. 9184 or other integrity violations in competing for the Project.

#### **5. Eligible Bidders**

- 5.1. Only Bids of Bidders found to be legally, technically, and financially capable will be evaluated.
- 5.2. Foreign ownership limited to those allowed under the rules may participate in this Project.
- 5.3. Pursuant to Section 23.4.1.3 of the 2016 revised IRR of RA No.9184, the Bidder shall have an SLCC that is at least one (1) contract similar to the Project the value of which, adjusted to current prices using the PSA’s CPI, must be at least equivalent to:
  - a. **The Bidder must have completed a single contract that is similar to this Project, equivalent to at least fifty percent (50%) of the ABC.**
  - OR**
  - b. **The bidder should have completed at least two (2) similar contracts and the aggregate contract amounts should be equivalent to at least the percentage of the ABC as required above; and the largest of these similar contracts must be equivalent to at least half of the percentage of the ABC as required above.**
- 5.4. The Bidders shall comply with the eligibility criteria under Section 23.4.1 of the 2016 IRR of RA No. 9184.

#### **6. Origin of Goods**

There is no restriction on the origin of goods other than those prohibited by a decision of the UN Security Council taken under Chapter VII of the Charter of the UN, subject to Domestic Preference requirements under **ITB** Clause 18.

#### **7. Subcontracts**

**The Procuring Entity has prescribed that subcontracting is not allowed.**

#### **8. Pre-Bid Conference**

The Procuring Entity will hold a pre-bid conference for this Project on the specified date and time and either at its physical address *Office of the Assistant Regional*

*Director, DepEd-CAR RO, Wangal, La Trinidad Benguet* as indicated in paragraph 6 of the **IB**.

## **9. Clarification and Amendment of Bidding Documents**

Prospective bidders may request for clarification on and/or interpretation of any part of the Bidding Documents. Such requests must be in writing and received by the Procuring Entity, either at its given address or through electronic mail indicated in the **IB**, at least ten (10) calendar days before the deadline set for the submission and receipt of Bids.

## **10. Documents comprising the Bid: Eligibility and Technical Components**

- 10.1. The first envelope shall contain the eligibility and technical documents of the Bid as specified in **Section VIII (Checklist of Technical and Financial Documents)**.
- 10.2. The Bidder's SLCC as indicated in **ITB** Clause 5.3 should have been completed within **five (5) years** prior to the deadline for the submission and receipt of bids.
- 10.3. If the eligibility requirements or statements, the bids, and all other documents for submission to the BAC are in foreign language other than English, it must be accompanied by a translation in English, which shall be authenticated by the appropriate Philippine foreign service establishment, post, or the equivalent office having jurisdiction over the foreign bidder's affairs in the Philippines. Similar to the required authentication above, for Contracting Parties to the Apostille Convention, only the translated documents shall be authenticated through an apostille pursuant to GPPB Resolution No. 13-2019 dated 23 May 2019. The English translation shall govern, for purposes of interpretation of the bid.

## **11. Documents comprising the Bid: Financial Component**

- 11.1. The second bid envelope shall contain the financial documents for the Bid as specified in **Section VIII (Checklist of Technical and Financial Documents)**.
- 11.2. If the Bidder claims preference as a Domestic Bidder or Domestic Entity, a certification issued by DTI shall be provided by the Bidder in accordance with Section 43.1.3 of the 2016 revised IRR of RA No. 9184.
- 11.3. Any bid exceeding the ABC indicated in paragraph 1 of the **IB** shall not be accepted.
- 11.4. For Foreign-funded Procurement, a ceiling may be applied to bid prices provided the conditions are met under Section 31.2 of the 2016 revised IRR of RA No. 9184.

## 12. Bid Prices

12.1. Prices indicated on the Price Schedule shall be entered separately in the following manner:

- a. For Goods offered from within the Procuring Entity's country:
  - i. The price of the Goods quoted EXW (ex-works, ex-factory, ex-warehouse, ex-showroom, or off-the-shelf, as applicable);
  - ii. The cost of all customs duties and sales and other taxes already paid or payable;
  - iii. The cost of transportation, insurance, and other costs incidental to delivery of the Goods to their final destination; and
  - iv. The price of other (incidental) services, if any, listed in the **BDS**.
- b. For Goods offered from abroad:
  - i. Unless otherwise stated in the **BDS**, the price of the Goods shall be quoted delivered duty paid (DDP) with the place of destination in the Philippines as specified in the **BDS**. In quoting the price, the Bidder shall be free to use transportation through carriers registered in any eligible country. Similarly, the Bidder may obtain insurance services from any eligible source country.
  - ii. The price of other (incidental) services, if any, as listed in **BDS**.

## 13. Bid and Payment Currencies

13.1. For Goods that the Bidder will supply from outside the Philippines, the bid prices may be quoted in the local currency or tradeable currency accepted by the BSP at the discretion of the Bidder. However, for purposes of bid evaluation, Bids denominated in foreign currencies, shall be converted to Philippine currency based on the exchange rate as published in the BSP reference rate bulletin on the day of the bid opening.

13.2. Payment of the contract price shall be made in Philippine Pesos.

## 14. Bid Security

14.1. The Bidder shall submit a Bid Securing Declaration<sup>1</sup> or any form of Bid Security in the amount indicated in the **BDS**, which shall be not less than the percentage of the ABC in accordance with the schedule in the **BDS**.

---

<sup>1</sup> In the case of Framework Agreement, the undertaking shall refer to entering into contract with the Procuring Entity and furnishing of the performance security or the performance securing declaration within ten (10) calendar days from receipt of Notice to Execute Framework Agreement.

- 14.2. The Bid and bid security shall be valid until **within sixty (60) calendar days from bid opening**. Any Bid not accompanied by an acceptable bid security shall be rejected by the Procuring Entity as non-responsive.

## **15. Sealing and Marking of Bids**

Each Bidder shall submit **one (1) copy (labelled as original copy)** of the first and second components of its Bid.

The Procuring Entity requests **two (2) additional hard copies (labelled as Copy 1 and Copy 2)** and/or electronic copies of the Bid. However, failure of the Bidders to comply with the said request shall not be a ground for disqualification.

If the Procuring Entity allows the submission of bids through online submission or any other electronic means, the Bidder shall submit an electronic copy of its Bid, which must be digitally signed. An electronic copy that cannot be opened or is corrupted shall be considered non-responsive and, thus, automatically disqualified.

## **16. Deadline for Submission of Bids**

The Bidders shall submit on the specified date and time and either at its physical address or through online submission as indicated in paragraph 7 of the **IB**.

## **17. Opening and Preliminary Examination of Bids**

- 17.1. The BAC shall open the Bids in public at the time, on the date, and at the place specified in paragraph 9 of the **IB**. The Bidders' representatives who are present shall sign a register evidencing their attendance. In case videoconferencing, webcasting or other similar technologies will be used, attendance of participants shall likewise be recorded by the BAC Secretariat.

In case the Bids cannot be opened as scheduled due to justifiable reasons, the rescheduling requirements under Section 29 of the 2016 revised IRR of RA No. 9184 shall prevail.

- 17.2. The preliminary examination of bids shall be governed by Section 30 of the 2016 revised IRR of RA No. 9184.

## **18. Domestic Preference**

- 18.1. The Procuring Entity will grant a margin of preference for the purpose of comparison of Bids in accordance with Section 43.1.2 of the 2016 revised IRR of RA No. 9184.

## 19. Detailed Evaluation and Comparison of Bids

- 19.1. The Procuring BAC shall immediately conduct a detailed evaluation of all Bids rated “*passed*,” using non-discretionary pass/fail criteria. The BAC shall consider the conditions in the evaluation of Bids under Section 32.2 of the 2016 revised IRR of RA No. 9184.
- 19.2. If the Project allows partial bids, bidders may submit a proposal on any of the lots or items, and evaluation will be undertaken on a per lot or item basis, as the case maybe. In this case, the Bid Security as required by **ITB** Clause 15 shall be submitted for each lot or item separately.
- 19.3. The descriptions of the lots or items shall be indicated in **Section VII (Technical Specifications)**, although the ABCs of these lots or items are indicated in the **BDS** for purposes of the NFCC computation pursuant to Section 23.4.2.6 of the 2016 revised IRR of RA No. 9184. The NFCC must be sufficient for the total of the ABCs for all the lots or items participated in by the prospective Bidder.
- 19.4. The Project shall be awarded as follows:  
  
**Option 2 – One Project having several items grouped into several lots, which shall be awarded as separate contracts per lot.**
- 19.5. Except for bidders submitting a committed Line of Credit from a Universal or Commercial Bank in lieu of its NFCC computation, all Bids must include the NFCC computation pursuant to Section 23.4.1.4 of the 2016 revised IRR of RA No. 9184, which must be sufficient for the total of the ABCs for all the lots or items participated in by the prospective Bidder. For bidders submitting the committed Line of Credit, it must be at least equal to ten percent (10%) of the ABCs for all the lots or items participated in by the prospective Bidder.

## 20. Post-Qualification

- 20.2. Within a non-extendible period of five (5) calendar days from receipt by the Bidder of the notice from the BAC that it submitted the Lowest Calculated Bid, the Bidder shall submit its latest income and business tax returns filed and paid through the BIR Electronic Filing and Payment System (eFPS) and other appropriate licenses and permits required by law and stated in the **BDS**.

## 21. Signing of the Contract

- 21.1. The documents required in Section 37.2 of the 2016 revised IRR of RA No. 9184 shall form part of the Contract. Additional Contract documents are indicated in the **BDS**.



## ***Section III. Bid Data Sheet***

# Bid Data Sheet

ITB Clause				
5.3	For this purpose, contracts similar to the Project shall be:  a. Contracts related to the Procurement of School Furniture			
7.1	Subcontracting is not allowed.			
12	The price of the Goods shall be quoted DDP <b>DepEd-CAR Regional Office</b> or the applicable International Commercial Terms (INCOTERMS) for this Project.			
14.1	The bid security shall be in the form of a <b>Bid Securing Declaration</b> , or any of the following forms and amounts:			
	Lot No.	Amount Cash, Cashier's / Manager's Check, Bank Draft/ Guarantee/ Irrevocable Letter of Credit (2%)	Surety bond callable upon demand issued by a surety or insurance company duly certified by the Insurance Commission (5%)	Bid Securing Declaration (Pursuant to GPPB Resolution No. 03-2012)
	1	1,802,992.00	4,507,480.00	Please see Section VIII
	2	320,597.88	801,494.70	
	<b>Note:</b> The Bid Security in the form of Cashier's/manager's check shall be payable to <b>DepEd-CAR Regional Office – Cash Section</b>			
19.3	The Project will be awarded by lot/s. The NFCC computation, if applicable, must be sufficient for all the lot/s or contract/s to be awarded to the Bidder:			
	<b>Lot</b>	<b>Items Name</b>	<b>Unit</b>	<b>Quantity</b>
	<b>School Furniture under CY 2024 BEFF School Furniture Program</b>			
	1	Elementary Individual Learner Table and Chair	set	15,950
		JHS Individual Learner Table and Chair	set	10,690
		SHS Individual Learner Table and Chair	set	1,360
		Teacher's Table and Chair	set	632
	2	Elementary Individual Learner Table and Chair	set	2,160
		JHS Individual Learner Table and Chair	set	2,205
		SHS Individual Learner Table and Chair	set	1,185
		Teacher's Table and Chair	set	126
				<b>90,149,600.00</b>
				<b>16,029,894.00</b>
	<b>NOTE:</b> List of Recipient Schools is attached as Annex B and can be downloaded from this link: <a href="https://tinyurl.com/SF2024LISTOFSCHOOLS">https://tinyurl.com/SF2024LISTOFSCHOOLS</a>			

20.2	<p>Within a non-extendible period of <b>five (5) calendar days</b> from receipt by the bidder of the notice from the BAC that it submitted the LCB, the Bidder shall submit copies of the following requirements:</p> <ol style="list-style-type: none"> <li><b>1. Latest income and business tax returns filed and paid through the BIR Electronic Filing and Payment System (eFPS)</b></li> <li><b>2. During the Post Qualification (Site Inspection), the LCB shall present the following:</b> <ol style="list-style-type: none"> <li>a. All licenses, permits, and other documents it submitted, such as SEC registration, DTI business name registration, Mayor’s permit, TIN, audited financial statements, etc.</li> <li>b. An actual sample of the items being offered</li> <li>c. Submit Project implementation timeline including plan for logistics arrangements.</li> </ol> </li> </ol> <p>a. <i><b>NOTE:</b> Failure to submit any of the post-qualification requirements on time, or finding against the veracity thereof, shall disqualify the bidder for award. Provided in the event that a finding against the veracity of any of the documents submitted is made, it shall cause the forfeiture of the bid security in accordance with Section 69 of the IRR of RA 9184.</i></p>
Others	Prospective Bidders <b>MAY</b> bring and present samples of finished products during the bid opening

## ***Section IV. General Conditions of Contract***

## 1. Scope of Contract

This Contract shall include all such items, although not specifically mentioned, that can be reasonably inferred as being required for its completion as if such items were expressly mentioned herein. All the provisions of RA No. 9184 and its 2016 revised IRR, including the Generic Procurement Manual, and associated issuances, constitute the primary source for the terms and conditions of the Contract, and thus, applicable in contract implementation. Herein clauses shall serve as the secondary source for the terms and conditions of the Contract.

This is without prejudice to Sections 74.1 and 74.2 of the 2016 revised IRR of RA No. 9184 allowing the GPPB to amend the IRR, which shall be applied to all procurement activities, the advertisement, posting, or invitation of which were issued after the effectivity of the said amendment.

Additional requirements for the completion of this Contract shall be provided in the **Special Conditions of Contract (SCC)**.

## 2. Advance Payment and Terms of Payment

2.1. Advance payment of the contract amount is provided under Annex “D” of the revised 2016 IRR of RA No. 9184.

2.2. The Procuring Entity is allowed to determine the terms of payment on the partial or staggered delivery of the Goods procured, provided such partial payment shall correspond to the value of the goods delivered and accepted in accordance with prevailing accounting and auditing rules and regulations. The terms of payment are indicated in the **SCC**.

## 3. Performance Security

Within ten (10) calendar days from receipt of the Notice of Award by the Bidder from the Procuring Entity but in no case later than prior to the signing of the Contract by both parties, the successful Bidder shall furnish the performance security in any of the forms prescribed in Section 39 of the 2016 revised IRR of RA No. 9184.

## 4. Inspection and Tests

The Procuring Entity or its representative shall have the right to inspect and/or to test the Goods to confirm their conformity to the Project specifications at no extra cost to the Procuring Entity in accordance with the Generic Procurement Manual. In addition to tests in the **SCC**, **Section IV (Technical Specifications)** shall specify what inspections and/or tests the Procuring Entity requires, and where they are to be conducted. The Procuring Entity shall notify the Supplier in writing, in a timely manner, of the identity of any representatives retained for these purposes.

All reasonable facilities and assistance for the inspection and testing of Goods, including access to drawings and production data, shall be provided by the Supplier to the authorized inspectors at no charge to the Procuring Entity.

## **5. Warranty**

- 6.1. In order to assure that manufacturing defects shall be corrected by the Supplier, a warranty shall be required from the Supplier as provided under Section 62.1 of the 2016 revised IRR of RA No. 9184.
- 6.2. The Procuring Entity shall promptly notify the Supplier in writing of any claims arising under this warranty. Upon receipt of such notice, the Supplier shall, repair or replace the defective Goods or parts thereof without cost to the Procuring Entity, pursuant to the Generic Procurement Manual.

## **6. Liability of the Supplier**

The Supplier's liability under this Contract shall be as provided by the laws of the Republic of the Philippines.

If the Supplier is a joint venture, all partners to the joint venture shall be jointly and severally liable to the Procuring Entity.

## ***Section V. Special Conditions of Contract***

## Special Conditions of Contract

GCC Clause	
	<p><b>a.</b> Date of Delivery: within one hundred fifty (150) calendar days from the receipt of Notice to Proceed (NTP)</p> <p><b>b.</b> Winning Bidder shall provide manpower requirements and schedule of: production, pre-delivery inspection and delivery within 10 calendar days upon receipt of Notice of Award</p> <p><b>Delivery and Documents –</b>            For purposes of the Contract, “EXW,” “FOB,” “FCA,” “CIF,” “CIP,” “DDP” and other trade terms used to describe the obligations of the parties shall have the meanings assigned to them by the current edition of INCOTERMS published by the International Chamber of Commerce, Paris. The Delivery terms of this Contract shall be as follows:  <i>In case of Goods supplied from abroad,</i> “the delivery terms applicable to the Contract are DDP delivered at the <b>Various Schools in CAR (attached as Annex B and the link provided in BDS)</b>. In accordance with INCOTERMS.”  <i>In case Goods supplied from within the Philippines,</i> “the delivery terms applicable to this Contract are delivered at <b>Various Schools in CAR (attached as Annex B and the link provided in BDS)</b>. Risk and title will pass from the Supplier to the Procuring Entity upon receipt and final acceptance of the Goods at their final destination.”            Delivery of the Goods shall be made by the Supplier in accordance with the terms specified in Section VI (Schedule of Requirements).</p> <p>For purposes of this Clause the Procuring Entity’s Representative at the <b>Project Sites is Engr. Christopher B. Hadsan, Regional Engineer, DepEd-CAR RO.</b>  <b>Incidental Services –</b> The Supplier is required to provide all of the following services, including additional services, if any, specified in Section VI. Schedule of Requirements:</p> <ol style="list-style-type: none"> <li>a. performance or supervision of on-site assembly and/or start-up of the supplied Goods;</li> <li>b. furnishing of tools required for assembly and/or maintenance of the supplied Goods;</li> <li>c. furnishing of a detailed operations and maintenance manual for each appropriate unit of the supplied Goods;</li> <li>d. performance or supervision or maintenance and/or repair of the supplied Goods, for a period of time agreed by the parties, provided that this service shall not relieve the Supplier of any warranty obligations under this Contract.</li> <li>e. Orientation of the Procuring Entity’s personnel on the place of delivery/installation on the assembly, start-up, operation, and preventive maintenance of the supplied Goods.</li> </ol>
	<p>The Contract price for the Goods shall include the prices charged by the Supplier for incidental services and shall not exceed the prevailing rates charged to other parties by the Supplier for similar services.</p>



**Spare Parts –**

The Supplier is required to provide all of the following materials, notifications, and information pertaining to spare parts manufactured or distributed by the Supplier:

- a. such spare parts as the Procuring Entity may elect to purchase from the Supplier, provided that this election shall not relieve the Supplier of any warranty obligations under this Contract; and
- b. in the event of termination of production of the spare parts:
  - i. advance notification to the Procuring Entity of the pending termination, in sufficient time to permit the Procuring Entity to procure needed requirements; and
  - ii. following such termination, furnishing at no cost to the Procuring Entity, the blueprints, drawings, and specifications of the spare parts, if requested.

The spare parts and other components required are listed in **Section VI (Schedule of Requirements)** and the cost thereof are included in the contract price.

The Supplier shall carry sufficient inventories to assure ex-stock supply of consumable spare parts or components for the Goods within the warranty period.

Spare parts or components shall be supplied as promptly as possible, but in any case, within 1 – 3 months of placing the order

**Packaging –**

The Supplier shall provide such packaging of the Goods as is required to prevent their damage or deterioration during transit to their final destination, as indicated in this Contract. The packaging shall be sufficient to withstand, without limitation, rough handling during transit and exposure to extreme temperatures, salt and precipitation during transit, and open storage. Packaging case size and weights shall take into consideration, where appropriate, the remoteness of the Goods' final destination and the absence of heavy handling facilities at all points in transit. The packaging, marking, and documentation within and outside the packages shall comply strictly with such special requirements as shall be expressly provided for in the Contract, including additional requirements, if any, specified below, and in any subsequent instructions ordered by the Procuring Entity.

The outer packaging must be clearly marked on at least four (4) sides as follows:  
Name of the Procuring Entity  
Name of the Supplier  
Contract Description

	<p>Final Destination  Gross weight  Any special lifting instructions  Any special handling instructions  Any relevant HAZCHEM classifications</p>
	<p>A packaging list identifying the contents and quantities of the package is to be placed on an accessible point of the outer packaging if practical. If not practical the packaging list is to be placed inside the outer packaging but outside the secondary packaging.</p> <p><b>Transportation</b> – Where the Supplier is required under Contract to deliver the Goods CIF, CIP, or DDP, transport of the Goods to the port of destination or such other named place of destination in the Philippines, as shall be specified in this Contract, shall be arranged and paid for by the Supplier, and the cost thereof shall be included in the Contract Price.</p> <p>Where the Supplier is required under this Contract to transport the Goods to a specified place of destination within the Philippines, defined as the Project Site, transport to such place of destination in the Philippines, including insurance and storage, as shall be specified in this Contract, shall be arranged by the Supplier, and related costs shall be included in the contract price.</p> <p>Where the Supplier is required under Contract to deliver the Goods CIF, CIP or DDP, Goods are to be transported on carriers of Philippine registry. In the event that no carrier of Philippine registry is available, Goods may be shipped by a carrier which is not of Philippine registry provided that the Supplier obtains and presents to the Procuring Entity certification to this effect from the nearest Philippine consulate to the port of dispatch. In the event that carriers of Philippine registry are available but their schedule delays the Supplier in its performance of this Contract the period from when the Goods were first ready for shipment and the actual date of shipment the period of delay will be considered force majeure.</p> <p>The Procuring Entity accepts no liability for the damage of Goods during transit other than those prescribed by INCOTERMS for DDP deliveries. In the case of Goods supplied from within the Philippines or supplied by domestic Suppliers risk and title will not be deemed to have passed to the Procuring Entity until their receipt and final acceptance at the final destination.</p> <p><b>Intellectual Property Rights</b> – The Supplier shall indemnify the Procuring Entity against all third-party claims of infringement of patent, trademark, or industrial design rights arising from use of the Goods or any part thereof.</p> <p><b>Liquidated Damages</b> - Under Section 68 of the 2016 Revised IRR of RA 9184.</p> <p>All contracts executed in accordance with the Act and this IRR shall contain a provision on liquidated damages which shall be payable by the contractor in case of breach thereof. For the procurement of Goods, Infrastructure Projects and Consulting Services, the amount of the liquidated damages shall be at least equal to one-tenth of one percent (0.001) of the cost of the unperformed portion</p>

	<p>for every day of delay. Once the cumulative amount of liquidated damages reaches ten percent (10%) of the amount of the contract, the Procuring Entity may rescind or terminate the contract, without prejudice to other courses of action and remedies available under the circumstances.</p>
2.2	<p><b>Schedule of Payment:</b></p> <p>Progress payment shall be allowed for the supplier upon accomplishment / delivery of at least 25% of the requirement of the contract</p> <p>Final payment shall be effected upon 100% delivery of all the requirements</p> <p>Three percent (3%) retention money shall be deducted for every progress payment and will be released one (1) year after acceptance by the Procuring Entity of the delivered goods or submission of surety bond equivalent to the retention money.</p>
4	<p><b>Delivery and Inspection:</b></p> <ol style="list-style-type: none"> <li>a. The DepED-CAR RO RIT shall conduct inspection during production and pre-delivery inspection.</li> <li>b. At least 1 set of school furniture that is inspected and accepted during the pre-delivery inspection shall be distributed to each school recipient.</li> <li>c. The school furniture shall be delivered door-to-door. The supplier shall be responsible for the transport of the school furniture from the manufacturer's plant up to the recipient school.</li> <li>d. All materials used in the school furniture to be delivered to the school shall be free from defects, poor finish or poor paint job, presence of termites or any wood boring insects, poor assembly, untreated wood, substandard material, imperfection and other analogous defects for the use of the students.</li> <li>e. Only school furniture with the best quality and workmanship shall be acceptable to the Department.</li> <li>f. All school furniture found to be with defects, imperfections, poor quality and poor workmanship shall be rejected by the Department at any stage of the contract implementation.</li> <li>g. The school furniture shall be fully assembled prior to its delivery.</li> <li>h. Delivery shall be during office hours (8:00-5:00). The Supplier shall not deliver goods on a Saturdays, Sundays or Holidays.</li> <li>i. Delivered school furniture at site shall be inspected by the school inspectorate team and accepted by the school property custodian and DepED-CAR RO personnel shall conduct post-delivery inspection.</li> </ol>

	<p>j. The Supplier shall be responsible in the preparation and completion of the Inspection and Acceptance Report (IAR) and the Inventory Transfer Receipt (ITR)</p> <p>k. The Delivery Receipt (DR) shall be signed by the school property custodian</p>
5	<p><b>Warranty</b> - Under Section 62.1 of the 2016 revised IRR of RA No. 9184.</p> <p>For the procurement of Goods, in order to assure that manufacturing defects shall be corrected by the supplier, a warranty security shall be required from the contract awardee for a minimum period of three (3) months, in the case of Expendable Supplies, or a minimum period of one (1) year, in the case of Non-expendable Supplies, after acceptance by the Procuring Entity of the delivered supplies.</p> <p>The obligation for the warranty shall be covered by either retention money in an amount equivalent to at least one percent (1%) but not to exceed five percent (5%) of every progress payment, or a special bank guarantee equivalent to at least one percent (1%) but not to exceed five percent (5%) of the total contract price. The said amounts shall only be released after the lapse of the warranty period or, in the case of Expendable Supplies, after consumption thereof: Provided, however, That the supplies delivered are free from patent and latent defects and all the conditions imposed under the contract have been fully met.</p> <p>The Supplier shall supply and deliver only the best furniture for the learners and teachers</p> <p>The Supplier warrants that any damage or defect in the goods delivered, the supplier shall automatically and immediately replace the same with no question at no cost to the school, DepEd or Government within two weeks from the time of the defects become apparent and reported by the school or the Department</p> <p>The supplier shall replace or immediately compensate the school for replacement of damaged goods, unassembled furniture, or any other defects attributable to the delivery and factory defect of the items delivered within two years from delivery, excepts for damages caused while being used by the learners in the school</p> <p>Supplier must immediately replace defective furniture and deliver its replacement without any cost with one week from the reported presence of defects. Supplier cannot deny or refuse the immediate replacement of the reported patently defective goods delivered to the school reasoning the goods were accepted by the school who are not experts to determine the quality of the goods</p> <p>Failure to do so, will be a valid ground to terminate the contract for default and cause the blacklisting of the supplier from participating in any government contracts for a period of 5 years</p>

## ***Section VI. Schedule of Requirements***

The delivery schedule expressed as weeks/months stipulates hereafter a delivery date which is the date of delivery to the project site/s.

### **Lot 1**

<b>Item No.</b>	<b>Items</b>	<b>Division</b>	<b>No. of School Sites</b>	<b>unit</b>	<b>QTY</b>	<b>Delivered, Weeks/ Months</b>
1	Elementary Individual Learner Table and Chair	Apayao	1	set	-	<i>Delivery of the Goods is required within 150 calendar days after receipt of the Notice to Proceed</i>
	JHS Individual Learner Table and Chair				-	
	SHS Individual Learner Table and Chair				240	
	Teacher's Table and Chair				6	
2	Elementary Individual Learner Table and Chair	Benguet	17	set	2,600	
	JHS Individual Learner Table and Chair				1,350	
	SHS Individual Learner Table and Chair				360	
	Teacher's Table and Chair				98	
3	Elementary Individual Learner Table and Chair	Ifugao	38	set	5,400	
	JHS Individual Learner Table and Chair				3,060	
	SHS Individual Learner Table and Chair				240	
	Teacher's Table and Chair				194	
4	Elementary Individual Learner Table and Chair	Kalinga	23	set	1,965	
	JHS Individual Learner Table and Chair				2,680	
	SHS Individual Learner Table and Chair				320	
	Teacher's Table and Chair				112	
5	Elementary Individual Learner Table and Chair	Mt Province	31	set	3,555	
	JHS Individual Learner Table and Chair				2,250	
	SHS Individual Learner Table and Chair				-	
	Teacher's Table and Chair				129	
6	Elementary Individual Learner Table and Chair	Tabuk City	15	set	2,430	
	JHS Individual Learner Table and Chair				1,350	
	SHS Individual Learner Table and Chair				200	
	Teacher's Table and Chair				93	

**Lot 2**

<b>Item No.</b>	<b>Items</b>	<b>Division</b>	<b>No. of School Sites</b>	<b>unit</b>	<b>QTY</b>	<b>Delivered, Weeks/ Months</b>
1	Elementary Individual Learner Table and Chair	Abra	14	set	810	<i>Delivery of the Goods is required within 150 calendar days after receipt of the Notice to Proceed</i>
	JHS Individual Learner Table and Chair				1,260	
	SHS Individual Learner Table and Chair				1,105	
	Teacher's Table and Chair				73	
2	Elementary Individual Learner Table and Chair	Apayao	7	set	315	
	JHS Individual Learner Table and Chair				585	
	SHS Individual Learner Table and Chair				80	
	Teacher's Table and Chair				22	
3	Elementary Individual Learner Table and Chair	Baguio City	2	set	495	
	JHS Individual Learner Table and Chair				-	
	SHS Individual Learner Table and Chair				-	
	Teacher's Table and Chair				11	
4	Elementary Individual Learner Table and Chair	Benguet	3	set	540	
	JHS Individual Learner Table and Chair				360	
	SHS Individual Learner Table and Chair				-	
	Teacher's Table and Chair				20	

## ***Section VII. Technical Specifications***

# Technical Specifications

Item	Specification	Statement of Compliance
		<p><i>[Bidders must state here either “Comply” or “Not Comply” against each of the individual parameters of each Specification stating the corresponding performance parameter of the equipment offered. Statements of “Comply” or “Not Comply” must be supported by evidence in a Bidders Bid and cross-referenced to that evidence. Evidence shall be in the form of manufacturer’s un-amended sales literature, unconditional statements of specification and compliance issued by the manufacturer, samples, independent test data etc., as appropriate. A statement that is not supported by evidence or is subsequently found to be contradicted by the evidence presented will render the Bid under evaluation liable for rejection. A statement either in the Bidder's statement of compliance or the supporting evidence that is found to be false either during Bid evaluation, post-qualification or the execution of the Contract may be regarded as fraudulent and render the Bidder or supplier liable for prosecution subject to the applicable laws and issuances.]</i></p>



## DESIGNS AND TECHNICAL SPECIFICATIONS

- a. Individual Learners Table and Chair shall be the type of school furniture to be manufactured for the use of elementary and high school learners
- b. Teacher's Table and Chair shall be manufactured for the use of the teachers
- c. List of school recipients see link provided in the Bid Data Sheet
- d. The plans and technical specifications of the individual learners table and chair and teacher's table and chair shall follow the attached Design and Technical Specifications (see Annex A)
- e. Suppliers/manufacture must comply the with detailed technical specifications of learners table and chair and Teachers table and chair

Item No.	Specification	Statement of Compliance (Comply or not Comply)
1	<p><b>2. Technical Specifications of Learner's Table</b></p> <p><b>A. Table Top</b> 18mm Thk Top Board Round Corner's (1 side 1.0mm Thk High Pressure Laminate/ 1 Side Varnish Finishes on Marine Plywood)</p> <p><b>B. Edging</b> 1.0mm Thk PVC Edging, All Edges of Table Top</p> <p><b>C. Shelf</b> Metal Wire Mesh 4mm Thk x 50mm x 50mm</p> <p><b>D. Front Cover</b> 6mm Thk Front Cover (1 side 1.0mm Thk High Pressure Laminate / 1 Side Varnish Finishes on Marine Plywood)</p> <p><b>E. Main Frame</b> 1.0mm Thk x 20mm x 40mm Steel Tubular</p> <p><b>F. Secondary Frame</b> 1.0mm Thk x 20mm x 20mm Steel Tubular</p> <p><b>G. Adjustable Leveler</b> 8mmØ Thread with 38mmØ Plastic Base</p> <p><b>H. Connector/Flat Bar</b> 1mm Thk x 25mm x 50mm Steel Flat Bar (Table Top: 4pcs; Screw)</p> <p><b>I. Connection</b> <b>Wood to Steel:</b> Screw: E-Type Hex M6x13mm: (Table Top) Rivets: Blind Rivet (Front Cover) <b>Steel to Steel:</b> Full Welding Connection</p> <p><b>3. Schedule of Finishes</b></p> <p><b>A. Top Board</b> 1.0mm Thk High Pressure Laminate</p> <p><b>B. Edging</b> 1.0mm Thk PVC Edging, All Edges of Table Top</p> <p><b>C. Front Cover</b> 1.0mm Thk High Pressure Laminate</p> <p><b>D. Metal/Steel Tubular</b> Powder Coated (Black); Smooth, Glossy Finish</p> <p><b>E. Laminate Color</b></p>	

	<p>Pantone 729C or Color Hex #ba7c45 / RGB 186, 124, 69 / CMYK 0%, 33%, 63%, 27% with wood grain (Serano Beech or Equivalent)</p> <p><b>4. Dimensions of Learner's Table (mm)</b>  <b>(Tolerance ±10mm)</b></p> <p><b>A. Elementary</b>  Table Height: 670  Table Length: 600  Table Width: 400</p> <p><b>B. Secondary (JHS and SHS)</b>  Table Height: 730  Table Length: 600  Table Width: 400</p>	
	<p><b>1. Technical Specifications of Learner's Chair</b></p> <p><b>A. Seat</b>  Blow Molded Plastic  High-Density Polyethylene (HDPE)</p> <p><b>B. Backrest</b>  Blow Molded Plastic  High-Density Polyethylene (HDPE)</p> <p><b>C. Back Support</b>  BI Pipe Tube 1.0mm x 22mmØ</p> <p><b>D. Seat Support</b>  BI Pipe Tube 1.0mm x 19mmØ</p> <p><b>E. Back Leg</b>  BI Pipe Tube 1.0mm x 22mmØ</p> <p><b>F. Front Leg/Brace</b>  BI Pipe Tube 1.0mm x 22mmØ</p> <p><b>G. Lower Seat Support</b>  BI Pipe Tube 1.0mm x 19mmØ</p> <p><b>I. Cover Cap</b>  Plastic Glide</p> <p><b>HDPE to Steel</b>  Back HDPE to Steel – Self Tapping  Screw/Rivet  Seat HDPE to Steel – 1mm Thk 25mm x  30mm Flat Bar, M6 x 12</p> <p><b>2. Schedule of Finishes</b></p> <p><b>A. Seat Panel Backrest</b>  High-Density Polyethylene (HDPE) Plastic (Blow Molded)</p> <p><b>B. Metal/Steel Tubular</b>  Powder Coated (Black; Smooth, Glossy Finish)</p> <p><b>C. HDPE Color</b>  Refer to color code Pantone 4665C or Color Hex: #cda788 / RGB: 205, 167, 136 / CMYK 0%, 19%, 34%, 20%</p> <p><b>D. Markings</b></p>	

	<p>Minimum of 0.8mm depth embossed/molded official “DepEd LOGO” with the inscription “Department of Education” as per drawing</p> <p><b>3. Dimension of Learner’s Chair (mm)</b>  <b>(Tolerance ± 10mm)</b></p> <p><b>A. Elementary</b>  Seat Height: 390  Seat Depth: 380  Seat Width: 370  Back Rest Height: 700  Back Rest Width: 410</p> <p><b>B. Secondary (JHS and SHS)</b>  Seat Height: 430  Seat Depth: 380  Seat Width: 370  Back Rest Height: 800  Back Rest Width: 410</p>	
2	<p><b>1. Technical Specifications of Teacher’s Table</b></p> <p><b>A. Table Top</b>  18mm Thk Top Board Round Corner’s (1 side 1.0mm Thk High Pressure Laminate / 1 Side Varnish Finishes on Marine Plywood)</p> <p><b>B. Edging</b>  2.0mm Thk PVC Edging</p> <p><b>C. Side Cover</b>  6.0mm Thick Marine Plywood with High Pressure Laminate</p> <p><b>D. Front Cover</b>  6.0mm Thick Marine Plywood with High Pressure Laminate</p> <p><b>E. Pull Out Drawer</b>  <b>Drawer Face:</b> 1 side 1.0mm Thk High Pressure Laminate / 1 Side Varnish Finishes on 18mm Thick Marine Plywood  <b>Drawer Box:</b> 12mm Thk Marine Plywood w/ Solid Wood Edging Varnish Finished  <b>Drawer Lock:</b> 1 Lock only per Table  <b>Drawer Guide:</b> 400mm Long Rail Guide (Ball Bearing Type)</p> <p><b>F. Leg</b>  1.0mm Thk x 30mm x 30mm Steel Tubular</p> <p><b>G. Braces</b>  1.0mm Thk x 30mm x 30mm Steel Tubular</p> <p><b>H. Adjustable Leveler</b>  8mmØ Thread with 38mmØ Plastic Base  <b>Connection</b>  <b>Steel to Steel:</b> Full Welding  <b>Wood to Steel:</b> Threaded nuts E-Type Hex M6 x 13mm Length (Table Top) Blind Rivets (Front Cover / Side Cover)  <b>Wood to Wood:</b> Wood glue and finishing nails</p>	

<p><b>2. Schedule of Finishes</b></p> <p><b>A. Top Board</b> 18mm Top Board Round Corners (1 side 1.0mm Thk High Pressure Laminate / Side Varnish Finishes on Marine Plywood)</p> <p><b>B. Edging</b> 2.0mm Thick PVC Edging</p> <p><b>C. Metal/Steel Tubular</b> Powder Coated (Black); Smooth, Glossy Finish</p> <p><b>D. Laminate Color</b> Pantone 729C or Color Hex #ba7c45 / RGB 186, 124, 69 / CMYK 0%, 33%, 63%, 27% with wood grain (Serano Beech or Equivalent)</p> <p><b>3. Dimensions of Teacher’s Table (mm)</b> (Tolerance ± 10mm) Table Height: 750 Table Length: 1200 Table Width: 600</p>	
<p><b>1. Technical Specifications Teacher’s Chair</b></p> <p><b>A. Backrest</b> 18mm Thk Backrest Panel (0.9mm Thk High Pressure Laminate on Marine Plywood) w/ PVC Edging</p> <p><b>B. Seat</b> 18mm Thk Backrest Panel (0.9mm Thk High Pressure Laminate on Marine Plywood) w/ PVC Edging &amp; 5 Vent Holes (12mmØ)</p> <p><b>C. Backrest Support</b> 0.8mm Thk x 30mm x 30mm Steel Tubular</p> <p><b>D. Leg</b> 0.8mm Thk x 30mm x 30mm Steel Tubular</p> <p><b>E. Seat Support</b> 1mm Thk x 30mm x 30mm Steel Tubular</p> <p><b>F. Leg Brace</b> 1mm Thk x 30mm x 30mm Steel Tubular</p> <p><b>G. Footing</b> Hard Plastic (Black) <b>Edging:</b> PVC Edging <b>Connection</b> <b>Wood to Steel</b> 1mm Thk x 25mm x 75mm Flat Bar (For Backrest – 1) 1mm Thk x 25mm x 50mm Flat Bar (For Backrest – 2) 1mm Thk x 25mm x 50mm Flat Bar (Seat) M6 x 13mm E-nut and screw (wood insert) <b>Steel to Steel</b> Full welding – for tubular to tubular connections; Adequate Welding – For B.I. Pipe to Flat Bar Connections</p> <p><b>2. Schedule of Finishes</b></p> <p><b>A. Backrest &amp; Seat</b> High Pressure Wood Grain Laminate w/ PVC Edging</p> <p><b>B. Metal/Steel</b> Powder Coated (Black); Smooth, Glossy Finish</p>	

	<p><b>C. Laminate Color</b> Serano Beech or Equivalent</p> <p><b>D. Markings</b> Minimum of 0.8mm depth embossed/molded official “DepEd LOGO” with the inscription “Department of Education” as per drawing</p> <p><b>3. Dimensions of Teacher’s Chair (Tolerance of ± 10mm)</b>  Seat Height: 440  Seat Depth: 400  Seat Width: 400  Backrest Height: 850  Backrest Width: 350</p>	
--	---	--











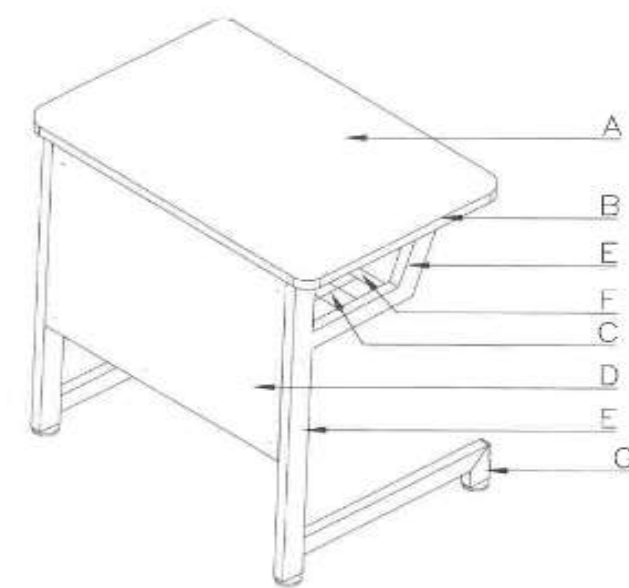

I hereby certify to comply with all of the above Technical Specifications

\_\_\_\_\_  
Name of Company/Bidder

\_\_\_\_\_  
Signature Over Printed Name of Representative

\_\_\_\_\_  
Date

ANNEX A – Detailed Technical Specifications and Design

<b>1</b>	<b>TECHNICAL SPECIFICATIONS OF LEARNER'S TABLE</b>			 <p style="text-align: center;"><b>ISOMETRIC VIEW OF LEARNER'S TABLE</b> SCALE 1:1</p>								
<b>MARK</b>	<b>COMPONENTS</b>	<b>SPECIFICATIONS</b>										
A	TABLE TOP	18MM THK TOP BOARD ROUND CORNER'S (1 SIDE 1.0MM THK HIGH PRESSURE LAMINATE/1 SIDE VARNISH FINISHES ON MARINE PLYWOOD)										
B	EDGING	1.0 MM THK PVC EDGING, ALL EDGES OF TABLE TOP										
C	SHELF	METAL WIRE MESH 4MMTHKX50X90										
D	FRONT COVER	5MM THK FRONT COVER (1 SIDE 1.0MM THK HIGH PRESSURE LAMINATE / 1 SIDE VARNISH FINISHES ON MARINE PLYWOOD)										
E	MAIN FRAME	1.0MMTHKX20MMX40MM STEEL TUBULAR										
F	SECONDARY FRAME	1.0MMTHKX20MMX20MM STEEL TUBULAR										
C	ADJUSTABLE LEVELER	8MMØ THREAD WITH 38MMØ PLASTIC BASE										
	CONNECTOR/FLAT BAR	1MMTHKX25MMX50MM STEEL FLAT BAR (TABLE TOP:4PCS; SCREW)										
	CONNECTION	WOOD TO STEEL: SCREW: E-TYPE HEX M6X13mm; (TABLE TOP) RIVETS: BLIND RIVET (FRONT COVER)  STEEL TO STEEL: FULL WELDING CONNECTION										
<b>2a</b>	<b>SCHEDULE OF FINISHES</b>											
TOP BOARD	1.0MM THK HIGH PRESSURE LAMINATE											
EDGING	1.0 MM THK PVC EDGING, ALL EDGES OF TABLE TOP											
FRONT COVER	1.0MM THK HIGH PRESSURE LAMINATE											
METAL/STEEL TUBULAR	POWDER COATED (BLACK); SMOOTH GLOSSY FINISH											
LAMINATE COLOR	PANTONE 729C OR COLOR HEX #d07c45 / RGB 185, 124, 69 / CMYK 0%, 33%, 63%, 27% WITH WOOD GRAIN (SERANO BEECH OR EQUIVALENT)											
	<b>3</b>	<b>DIMENSIONS OF LEARNER'S TABLE(mm)</b> (TOLERANCE ± 10mm)										
	<b>MARK</b>	<b>COMPONENTS</b>	<b>DIMENSIONS</b>									
			ELEMENTARY	SECONDARY								
	a	TABLE HEIGHT	670	730								
	b	TABLE LENGTH	600	600								
	c	TABLE WIDTH	400	400								
<table border="1" style="width: 100%; border-collapse: collapse;"> <tr> <td style="width: 10%; text-align: center;"><small>DEPARTMENT OF THE EDUCATION</small> <b>DepED</b> <small>DEPARTMENT OF EDUCATION REGIONAL OFFICE - CEBU</small></td> <td style="width: 15%; text-align: center;"><small>DESIGNED BY:</small>  RAYMOND G. RAMOS <small>ARCHITECT</small></td> <td style="width: 15%; text-align: center;"><small>FORWARDED APPROVAL</small>  ENGR. ERASMO S. RAMOS <small>CHIEF - DESIGN FACILITIES GROUP</small></td> <td style="width: 15%; text-align: center;"><small>APPROVED BY:</small>  DR. MARIA V. RAMOS <small>Undersecretary for School Administration and Logistics</small></td> <td style="width: 15%; text-align: center;"><small>ENGINEER BY:</small>  GM G. RAMOS <small>Undersecretary for Construction and Safety</small></td> <td style="width: 15%; text-align: center;"><small>PROJECT TITLE:</small> <b>LEARNER'S TABLE (WOOD &amp; STEEL)</b></td> <td style="width: 15%; text-align: center;"><small>DEPT. CREDIT:</small> TECHNICAL SPECIFICATION SCHEDULE OF FINISHES EDGING APPLICATION DIMENSIONS ISOMETRIC VIEW</td> <td style="width: 10%; text-align: center;"><small>SHEET NO.</small> 1 3</td> </tr> </table>					<small>DEPARTMENT OF THE EDUCATION</small> <b>DepED</b> <small>DEPARTMENT OF EDUCATION REGIONAL OFFICE - CEBU</small>	<small>DESIGNED BY:</small>  RAYMOND G. RAMOS <small>ARCHITECT</small>	<small>FORWARDED APPROVAL</small>  ENGR. ERASMO S. RAMOS <small>CHIEF - DESIGN FACILITIES GROUP</small>	<small>APPROVED BY:</small>  DR. MARIA V. RAMOS <small>Undersecretary for School Administration and Logistics</small>	<small>ENGINEER BY:</small>  GM G. RAMOS <small>Undersecretary for Construction and Safety</small>	<small>PROJECT TITLE:</small> <b>LEARNER'S TABLE (WOOD &amp; STEEL)</b>	<small>DEPT. CREDIT:</small> TECHNICAL SPECIFICATION SCHEDULE OF FINISHES EDGING APPLICATION DIMENSIONS ISOMETRIC VIEW	<small>SHEET NO.</small> 1 3
<small>DEPARTMENT OF THE EDUCATION</small> <b>DepED</b> <small>DEPARTMENT OF EDUCATION REGIONAL OFFICE - CEBU</small>	<small>DESIGNED BY:</small>  RAYMOND G. RAMOS <small>ARCHITECT</small>	<small>FORWARDED APPROVAL</small>  ENGR. ERASMO S. RAMOS <small>CHIEF - DESIGN FACILITIES GROUP</small>	<small>APPROVED BY:</small>  DR. MARIA V. RAMOS <small>Undersecretary for School Administration and Logistics</small>	<small>ENGINEER BY:</small>  GM G. RAMOS <small>Undersecretary for Construction and Safety</small>	<small>PROJECT TITLE:</small> <b>LEARNER'S TABLE (WOOD &amp; STEEL)</b>	<small>DEPT. CREDIT:</small> TECHNICAL SPECIFICATION SCHEDULE OF FINISHES EDGING APPLICATION DIMENSIONS ISOMETRIC VIEW	<small>SHEET NO.</small> 1 3					

# DEPED ELEMENTARY SINGLE LEARNER'S TABLE

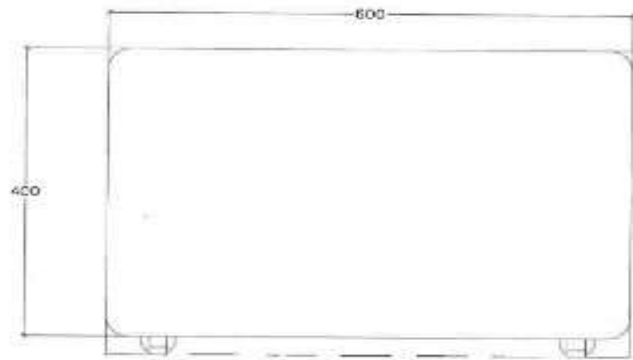

TOP VIEW

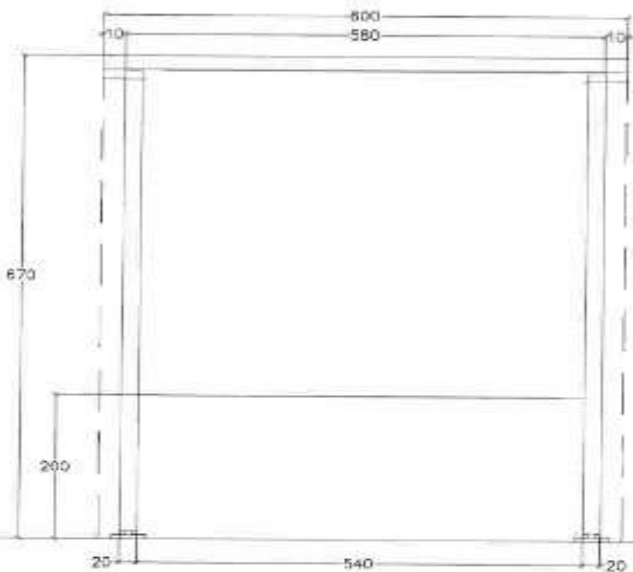

FRONT VIEW

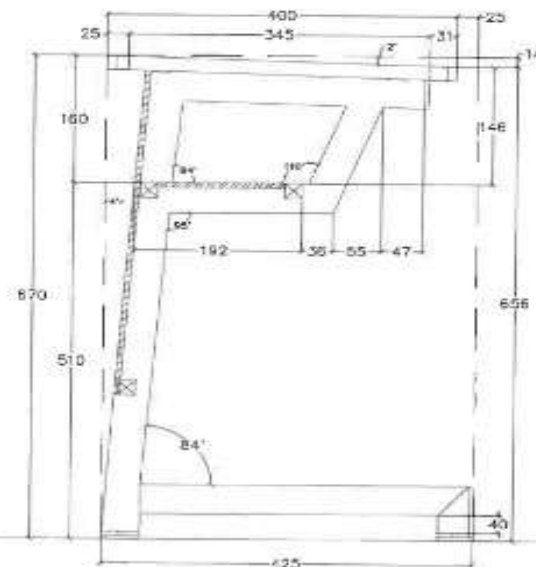

SIDE SECTION VIEW

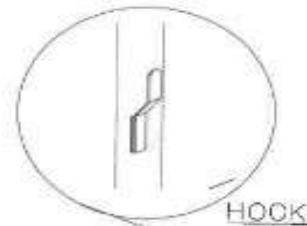

HOOK

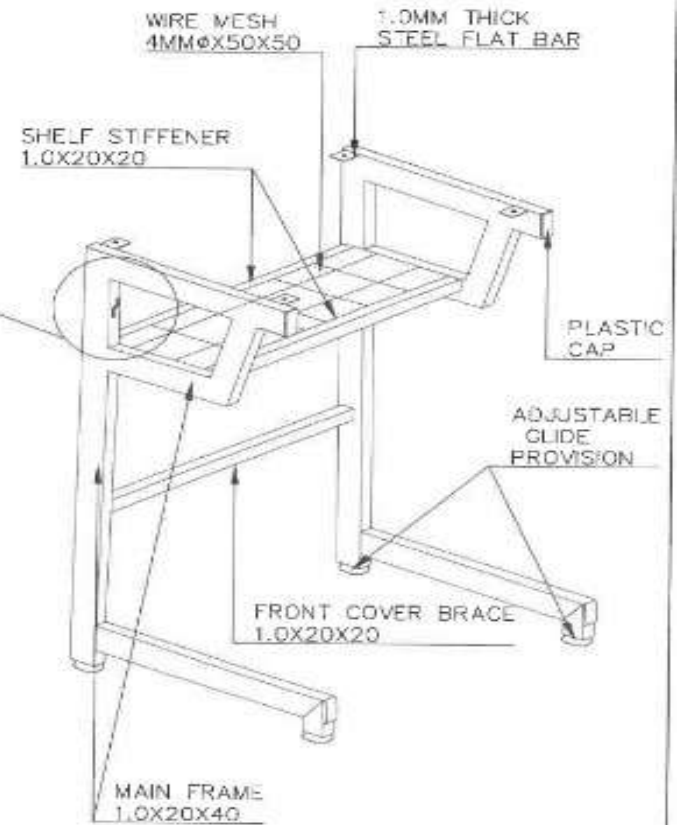

TABLE FRAMING PERSPECTIVE VIEW

<p>DEPARTMENT OF EDUCATION BUREAU OF FACILITIES DIVISION MERRILL AVENUE, PASIG CITY</p>	<p>DESIGNED BY: <i>[Signature]</i> ENR. LORNEO E. ALARON ABC 0221</p>	<p>RECOMMENDING APPROVAL: <i>[Signature]</i> ENR. JOSEPH B. BANGAL ENR - CASER INDUSTRY DIVISION</p>	<p>APPROVED BY: <i>[Signature]</i> ENR. MARIO V. SORIANO III Administrative Services and Facilities</p>	<p>CONCEPT DL: <i>[Signature]</i> ENR. JOSE B. BANGAL Administrative Services and Facilities</p>	<p>PROJECT TITLE: <b>LEARNER'S TABLE (WOOD &amp; STEEL)</b></p>	<p>SHEET CONTENTS: TOP VIEW FRONT VIEW SIDE SECTION VIEW FRAMING PERSPECTIVE VIEW</p>	<p>SHEET NO: 2 3</p>

DEPED SECONDARY SINGLE LEARNER'S TABLE



TOP VIEW

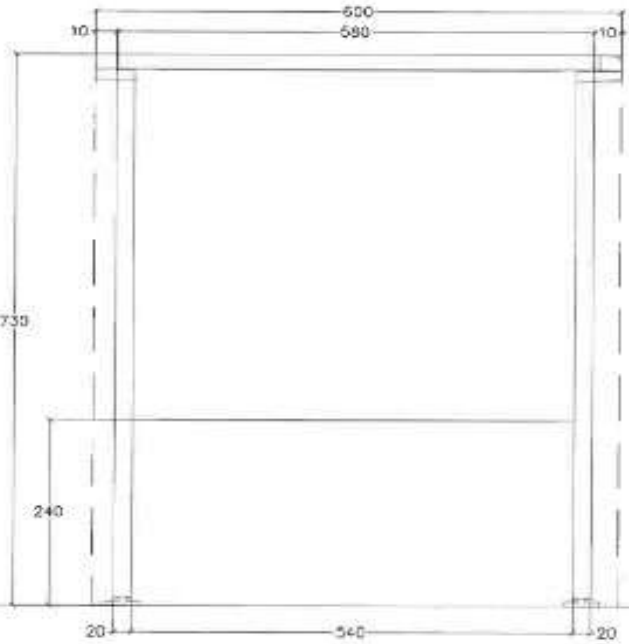

FRONT VIEW

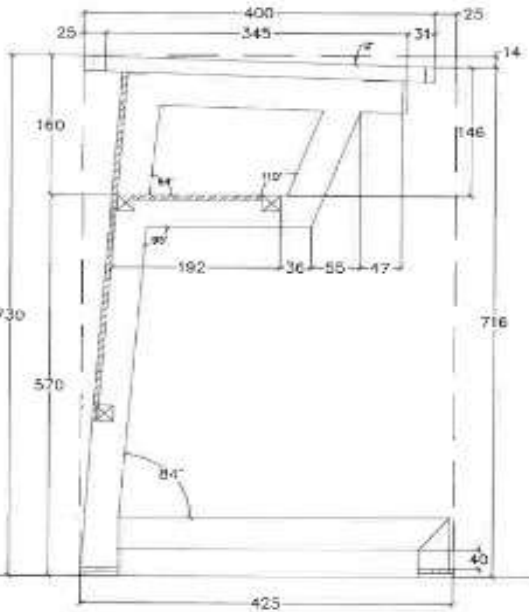

SIDE SECTION VIEW

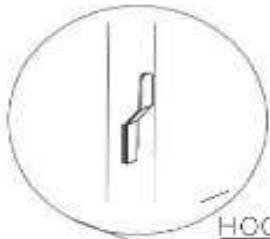

HOOK

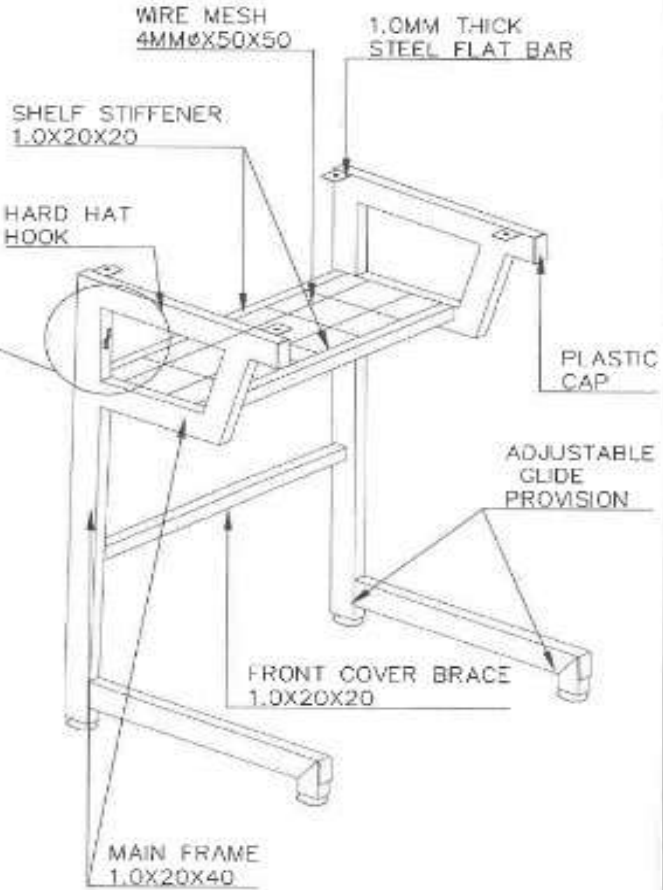

TABLE FRAMING PERSPECTIVE VIEW

<p>DEPARTMENT OF EDUCATION BUREAU OF TECHNICAL EDUCATION MANILA OFFICE</p>	<p>DESIGNED BY</p> <p><i>[Signature]</i> ENGR. ARMANDO C. KASANO 450-821</p>	<p>RECOMMENDING APPROVAL</p> <p><i>[Signature]</i> ENGR. ARMANDO C. KASANO ONLY IN CONNECTION WITH THIS PROJECT</p>	<p>APPROVED BY</p> <p><i>[Signature]</i> TRINIDAD V. SORIANO II Intermediary for School Installation and Facilities</p>	<p>DESIGNED BY</p> <p><i>[Signature]</i> GEM M. DOMINGO Administrative for Curriculum and Facilities</p>	<p>PROJECT TITLE</p> <p>LEARNER'S TABLE (WOOD &amp; STEEL)</p>	<p>SHEET NO.</p> <p>TOP VIEW FRONT VIEW SIDE SECTION VIEW FRAMING PERSPECTIVE VIEW</p>	<p>SHEET NO.</p> <p>3 3</p>





ISOMETRIC VIEW OF LEARNER'S CHAIR  
SCALE

DIMENSIONS OF LEARNER'S CHAIR (mm)  
(TOLERANCE  $\pm 10$ mm)

COMPONENTS	DIMENSIONS	
	ELEMENTARY	SECONDARY
SEAT HEIGHT	390	430
SEAT DEPTH	380	380
SEAT WIDTH	370	370
BACK REST HEIGHT	700	800
BACK REST WIDTH	410	410

1 TECHNICAL SPECIFICATIONS OF LEARNER'S CHAIR		
MARK	COMPONENTS	SPECIFICATIONS
A	SEAT	BLOW MOLDED PLASTIC HIGH-DENSITY POLYETHYLENE (HDPE)
B	BACKREST	BLOW MOLDED PLASTIC HIGH-DENSITY POLYETHYLENE (HDPE)
C	BACK SUPPORT	BI PIPE TUBE 1.0MMX22MM $\phi$
D	SEAT SUPPORT	BI PIPE TUBE 1.0MMX19MM $\phi$
E	BACK LEG	BI PIPE TUBE 1.0MMX22MM $\phi$
F	FRONT LEG/BRACE	BI PIPE TUBE 1.0MMX22MM $\phi$
G	LOWER SEAT SUPPORT	BI PIPE TUBE 1.0MMX19MM $\phi$
I	COVER CAP	PLASTIC GLIDE
	HDPE TO STEEL:	BACK HDPE TO STEEL - SELF TAPPING SCREW/RIVET
		SEAT HDPE TO STEEL - 1MM THK 25MMX30MM FLAT BAR, M8X12

SCHEDULE OF FINISHES

SEAT PANEL BACKREST	HIGH-DENSITY POLYETHYLENE (HDPE) PLASTIC (BLOW MOLDED)
METAL/STEEL TUBULAR	POWDER COATED (BLACK); SMOOTH, GLOSSY FINISH
HDPE COLOR	REFER TO COLOR CODE PANTONE 4655C OR COLOR HEX: #66a788 / RGB: 205, 167, 136 / CMYK: 0%, 19%, 34%, 20%

	 ENGR. ANABELLE E. BERNAL ARC/TEC	 ENGR. FRANCISCO M. GLEISING III DIRECTOR - COLLEGE FACILITIES DIVISION	 ENGR. ROMEO SUPERVISOR OF CONSTRUCTION and Building	PROJECT TITLE: <b>LEARNER'S CHAIR (HDPE &amp; STEEL)</b>	SHEET CONTENTS: TECHNICAL SPECIFICATION SCHEDULE OF FINISHES EDGE/D APPLICATION DIMENSIONS ISOMETRIC VIEW	SHEET NO: 1 5
--	---	---	--	---	--	---------------------

# DEPED ELEMENTARY LEARNER'S CHAIR

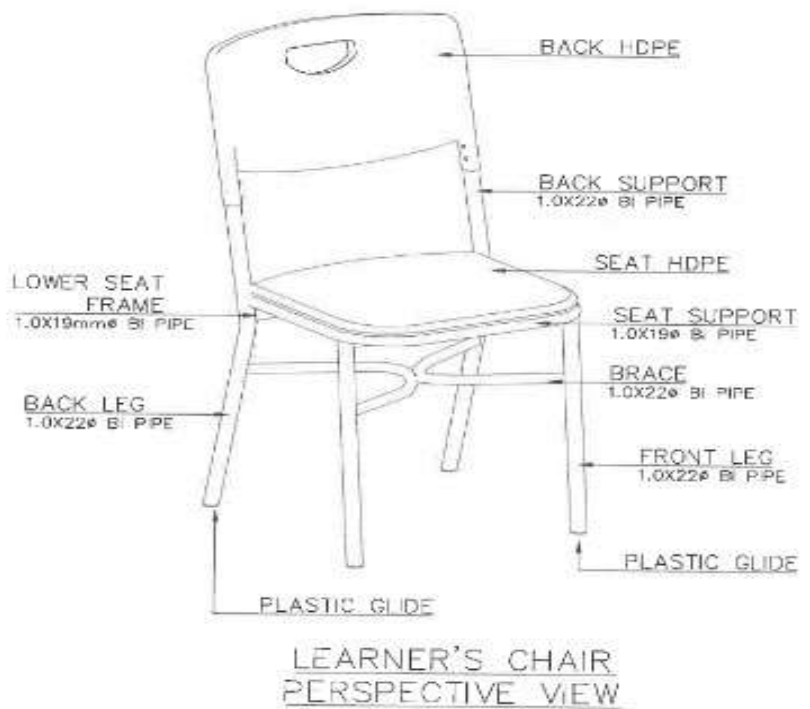
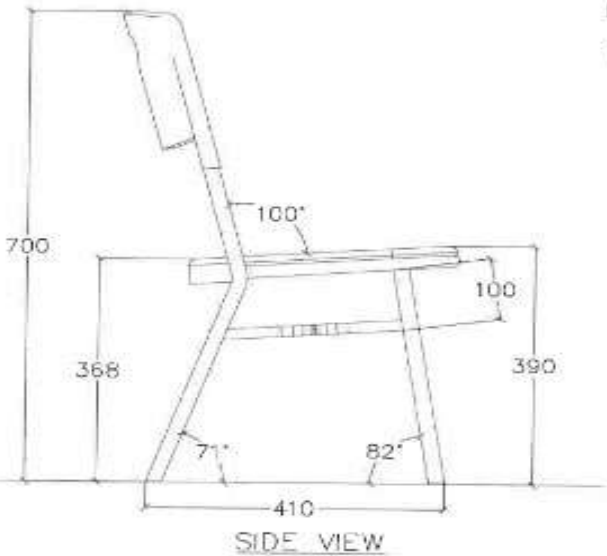
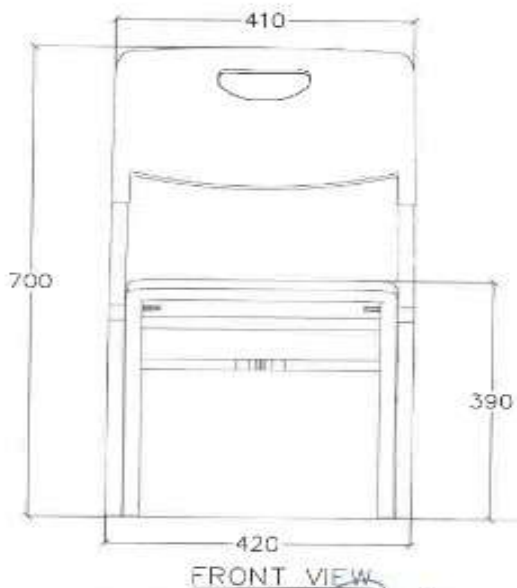
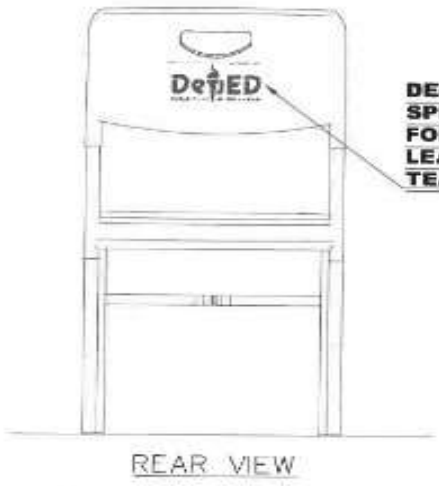
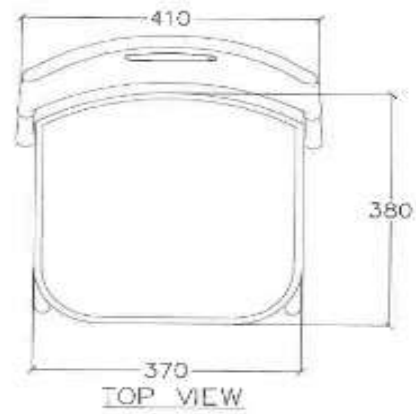

<p>DEPARTMENT OF EDUCATION SCHOOL DIVISION OFFICE MARICORIN, CALABARZON</p>	<p>DESIGN BY: <i>[Signature]</i> LET RICHARD G. ALARDO ARCHITECT</p>	<p>PROVIDING MATERIAL: <i>[Signature]</i> LUCAS ANTONIO S. RIVERA CMT - (C) 2018 - VARIOUS DESIGN</p>	<p>APPROVED BY: <i>[Signature]</i> ERAPAC Y. DOMINA Undersecretary for School Infrastructure and Facilities</p>	<p>COMPLETED BY: <i>[Signature]</i> SMA G. DOMINGO Undersecretary for Curriculum and Teaching</p>	<p>PROJECT TITLE: LEARNER'S CHAIR (HDPE &amp; STEEL)</p>	<p>SHEET CONTENT: ELEMENTARY LEARNER'S CHAIR - PERSPECTIVE VIEW - TOP VIEW - REAR VIEW - FRONT VIEW - SIDE VIEW</p>	<p>SHEET NO. 2 5</p>
	<p>42</p>						

# DEPED ELEMENTARY LEARNER'S CHAIR

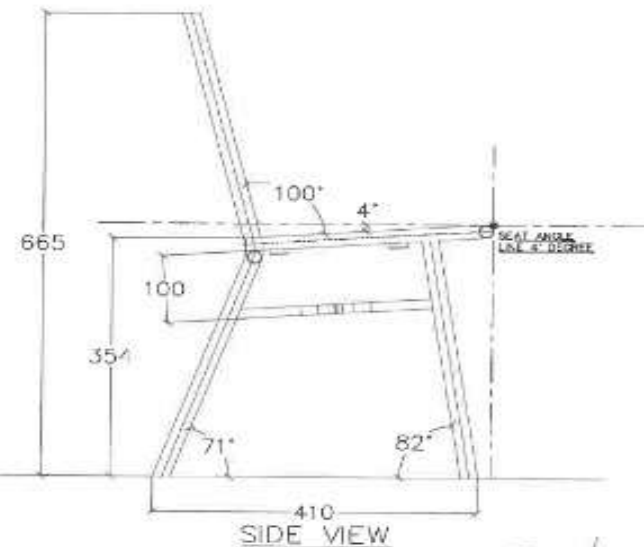
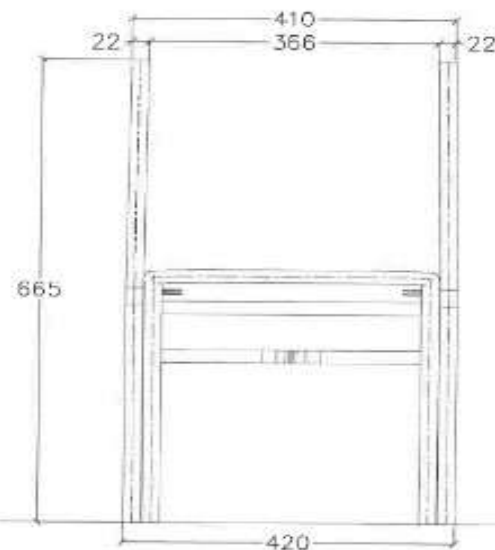
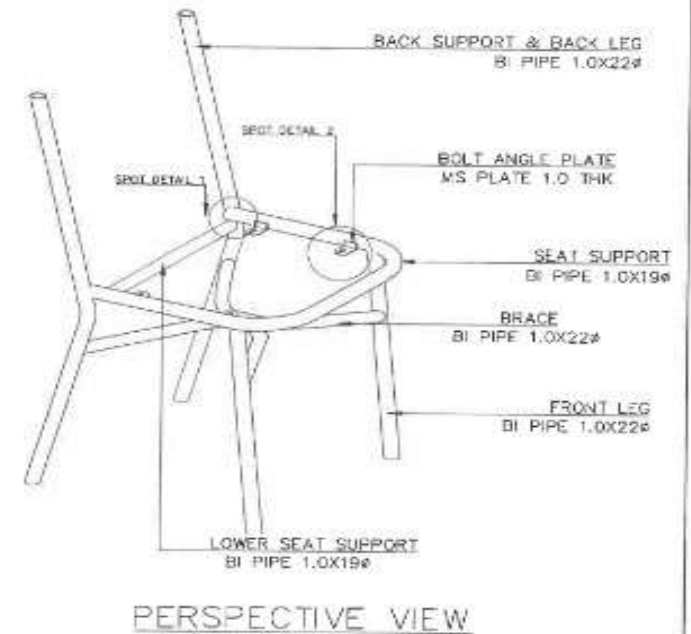
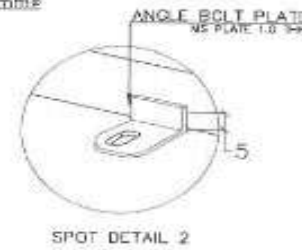
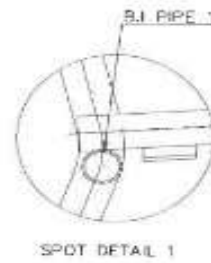
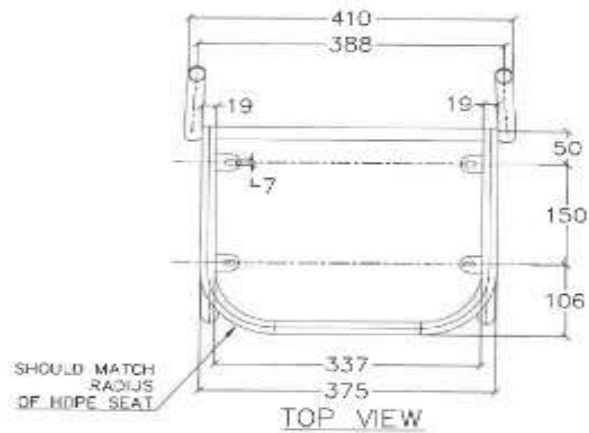

<p>DEPARTMENT OF EDUCATION DILIGENTE LITES BESOR MUNICIPALITY, DAVAO CITY</p>	DESIGNED BY:  JET RAYMOND G. ALARCO ARCHITECT	RECHECKING APPROVAL:  ENGR. JAMES L. LUNA CHIEF - DIVISION IN-CHARGE	APPROVED BY:  EDUARDO V. BENSING II Superintendent of School Inspections and Facilities	CONSULTED BY:  GINA G. SORIANO Instructor in Curriculum and Instruction	PROJECT TITLE: LEARNER'S CHAIR (HOPE & STEEL)	SHEET CONTENTS: - CHAIR FRAME (TOP FRONT, SIDE VIEW) - PERSPECTIVE VIEW - DETAILS	SHEET NO: 3 5
---	--	---	---	--	---	--	---------------------

# DEPED SECONDARY LEARNER'S CHAIR

**DEPED LOGO SPECIFICATIONS FOR ALL LEARNER AND TEACHER'S CHAIR**

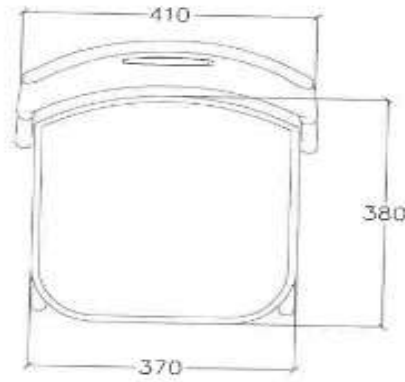

TOP VIEW

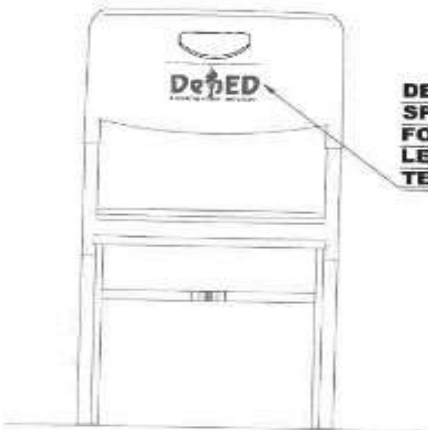

REAR VIEW



FRONT VIEW

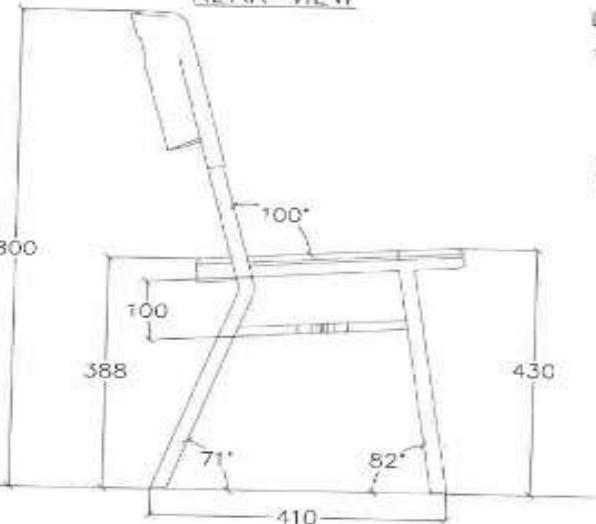

SIDE VIEW

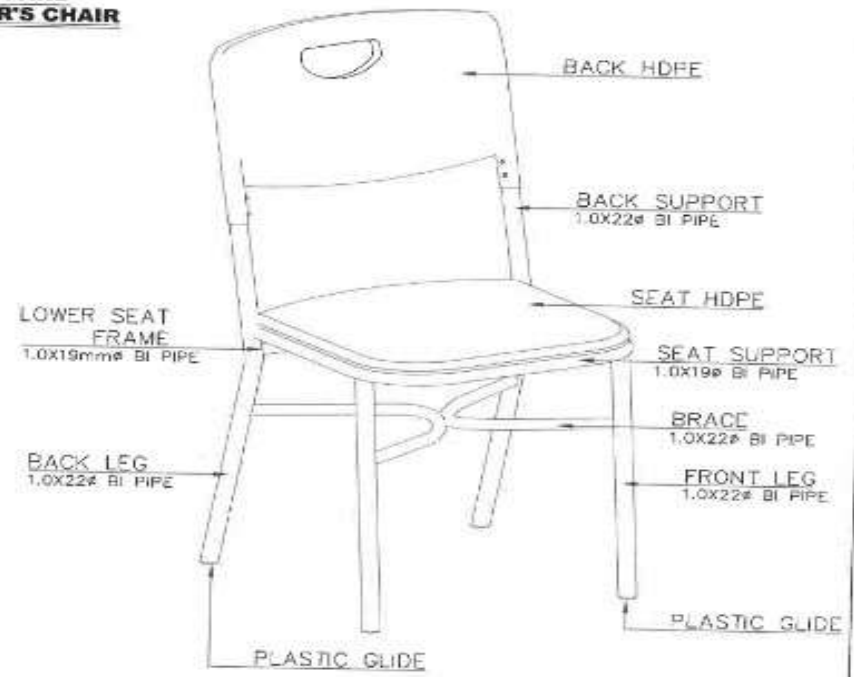

LEARNER'S CHAIR PERSPECTIVE VIEW

<p>DEPARTMENT OF EDUCATION EDUCATION DIVISION GENERAL SERVICES DIVISION</p>	<p>DESIGNED BY: <i>[Signature]</i> JEAN MARCO E. ARANDA ARCHITECT</p>	<p>REVISIONS APPROVAL: <i>[Signature]</i> ENRICA MARQUEZ CHIEF OF DESIGN FACTORY DESIGN</p>	<p>APPROVED BY: <i>[Signature]</i> MARCO V. DENING III DIRECTOR OF GENERAL SERVICES DIVISION</p>	<p>APPROVED BY: <i>[Signature]</i> MARCO V. DENING III DIRECTOR OF GENERAL SERVICES DIVISION</p>	<p>PROJECT FILE: LEARNER'S CHAIR (HDPE &amp; STEEL)</p>	<p>SHEET CONTENTS</p> <p>SECONDARY LEARNER'S CHAIR - PERSPECTIVE VIEW - TOP VIEW - REAR VIEW - FRONT VIEW - SIDE VIEW</p>	<p>SHEET NO.</p> <p>4 5</p>
	<p>44</p>						



# DEPED SECONDARY LEARNER'S CHAIR

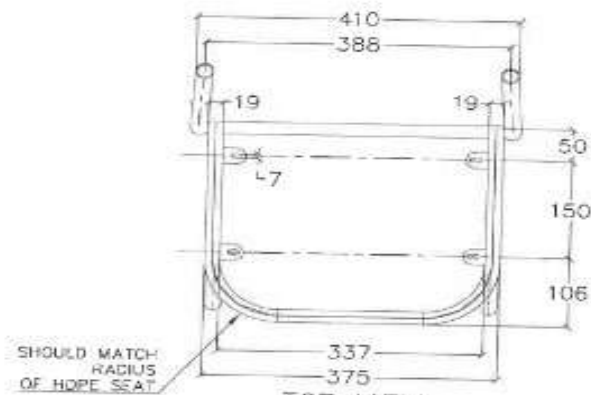

TOP VIEW



SPOT DETAIL 1

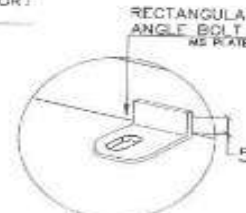

SPOT DETAIL 2

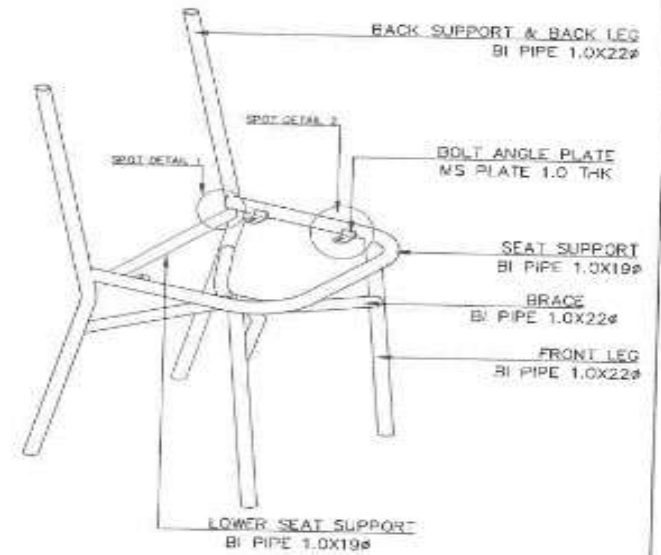

PERSPECTIVE VIEW

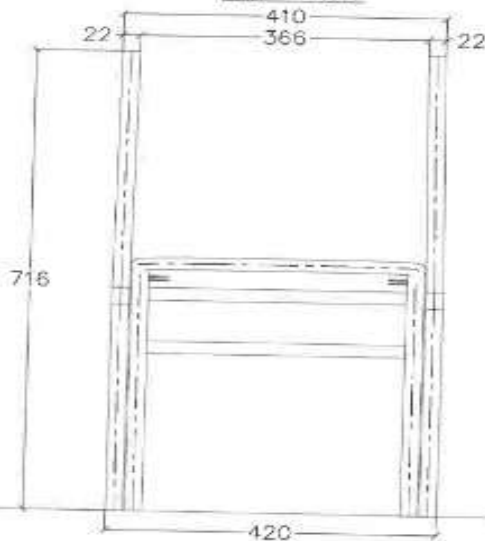

FRONT VIEW

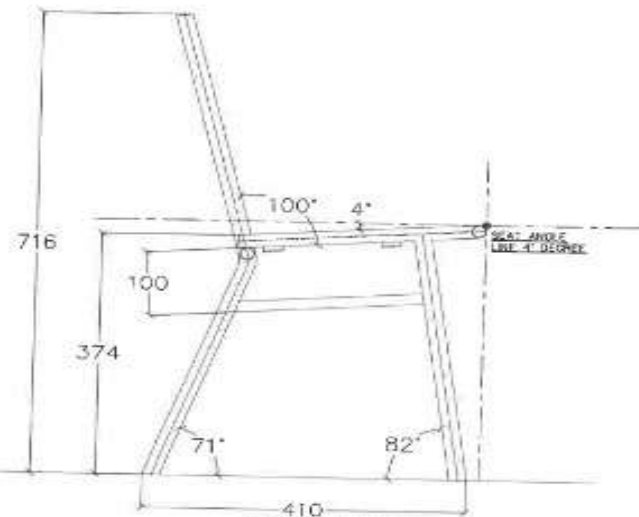

SIDE VIEW

<p>DEPED DEPARTMENT OF EDUCATION DIVISION OFFICE - CALABARZON MARICUARA PROVINCE</p>	<p>DESIGNED BY: <i>[Signature]</i> ENRICO G. ALANSO ARCHITECT</p>	<p>ENGINEERING APPROVAL: <i>[Signature]</i> ENRICO G. ALANSO ENR - REGIONAL FACILITIES DIVISION</p>	<p>APPROVED BY: <i>[Signature]</i> ENRICO G. ALANSO III ENR - REGIONAL FACILITIES DIVISION</p>	<p>CONSIGNED BY: <i>[Signature]</i> ENRICO G. ALANSO ENR - REGIONAL FACILITIES DIVISION</p>	<p>PROJECT TITLE: LEARNER'S CHAIR (HOPE &amp; STEEL)</p>	<p>SHEET CONTENTS: SECONDARY LEARNER'S CHAIR -CHAIR FRAME (FRONT/BACK VIEW) -PERSPECTIVE VIEW -DETAILS</p>	<p>SHEET NO. 5 5</p>

1 TECHNICAL SPECIFICATIONS OF TEACHER'S TABLE		
MARK	COMPONENTS	SPECIFICATIONS
A	TABLE TOP	18MM THK TOP BOARD ROUND CORNER'S (1 SIDE 1.0MM THK HIGH PRESSURE LAMINATE /1 SIDE VARNISH FINISHES ON MARINE PLYWOOD)
B	EDGING	2.0MM THICK PVC EDGING
C	SIDE COVER	6.0MM THICK MARINE PLYWOOD W/ HIGH PRESSURE LAMINATE
D	FRONT COVER	6.0MM THICK MARINE PLYWOOD W/ HIGH PRESSURE LAMINATE
E	PULL OUT DRAWER	DRAWER FACE : 1 SIDE 1.0MM THK HIGH PRESSURE LAMINATE / 1 SIDE VARNISH FINISHES ON 18MM THICK MARINE PLYWOOD DRAWER BOX : 12mm THK MARINE PLYWOOD W/ SOLID WOOD EDGING VARNISH FINISHED DRAWER LOCK : 1 LOCK ONLY PER TABLE,
	DRAWER GUIDE	400MM LONG RAIL GUIDE (BALL BEARING TYPE)
F	LEG	1.0MMTHKX30MMX30MM STEEL TUBULAR
G	BRACES	1.0MMTHKX30MMX30MM STEEL TUBULAR
H	ADJUSTABLE LEVELER	6MMØ THREAD WITH 38MMØ PLASTIC BASE
	CONNECTION	STEEL TO STEEL: FULL WELDING WOOD TO STEEL: THREADED NUTS E-TYPE HEX M6 X13mm LENGTH (TABLE TOP) BLIND RIVETS ( FRONT COVER / SIDE COVER ) WOOD TO WOOD: WOOD GLUE AND FINISHING NAILS

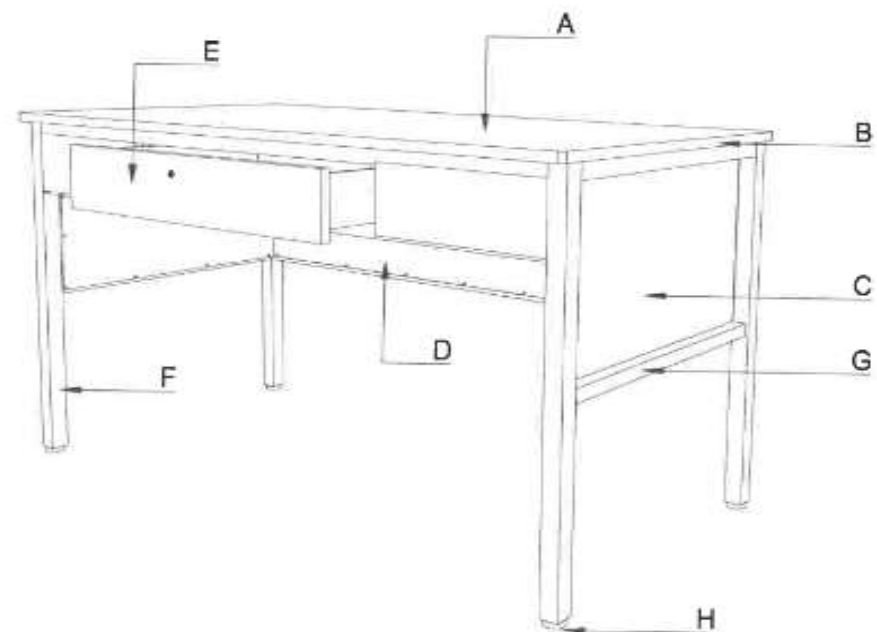

ISOMETRIC VIEW OF TEACHER'S TABLE  
SCALE

2a SCHEDULE OF FINISHES	
TOP BOARD	18MM THK TOP BOARD ROUND CORNER'S (1 SIDE 1.0MM THK HIGH PRESSURE LAMINATE /1 SIDE VARNISH FINISHES ON MARINE PLYWOOD)
EDGING	2.0MM THICK PVC EDGING
METAL/STEEL TUBULAR	POWDER COATED (BLACK); SMOOTH, GLOSSY FINISH
LAMINATE COLOR	PANTONE 729C OR COLOR HEX #9a7c45 / RGB 156, 124, 69 / CMYK 0%, 33%, 63%, 27% WITH WOOD GRAIN (SERANO BEECH OR EQUIVALENT)

3 DIMENSIONS OF TEACHER'S TABLE (mm) (TOLERANCE ± 10mm)		
MARK	COMPONENTS	DIMENSIONS
a	TABLE HEIGHT	750
b	TABLE LENGTH	1200
c	TABLE WIDTH	600

	DESIGNED BY: <i>[Signature]</i>	APPROVED BY: <i>[Signature]</i>	DESIGNED BY: <i>[Signature]</i>	PROJECT TITLE: TEACHER'S TABLE (WOOD & STEEL)	DATE: _____	SHEET CONTENT: TECHNICAL SPECIFICATION, SCHEDULE OF FINISHES, DIMENSIONS, ISOMETRIC VIEW SHEET NO: 1 TOTAL SHEETS: 5
	REP. MANOY G. A. SORIANO ARCHITECT	DIV. ENGR. R. A. SORIANO CHIEF - DESIGN FACILITIES DIVISION	DIV. ENGR. R. A. SORIANO CHIEF - DESIGN FACILITIES DIVISION	DIV. ENGR. R. A. SORIANO CHIEF - DESIGN FACILITIES DIVISION		

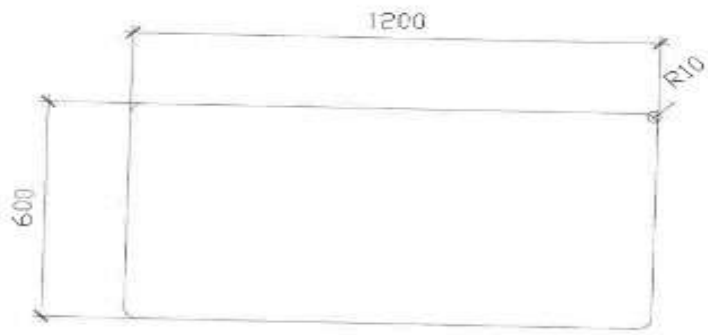

PLAN



PERSPECTIVE

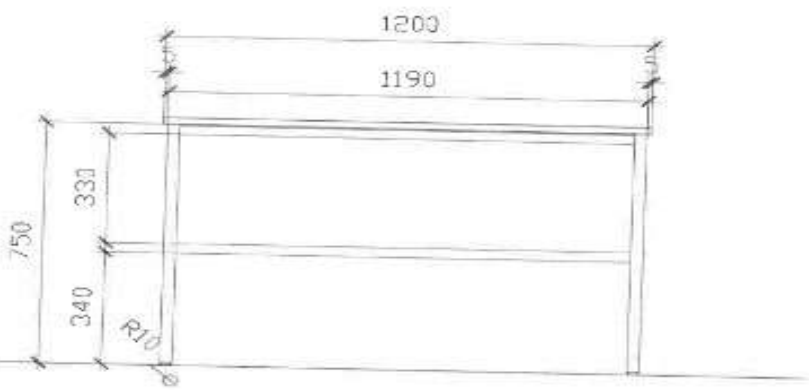

FRONT ELEV.

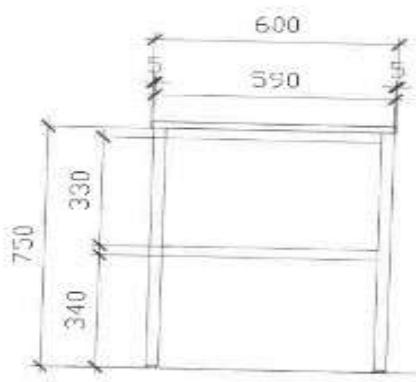

RIGHT SIDE ELEVATION

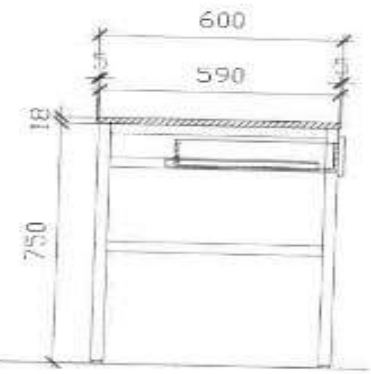

SECTION

	DRAWN BY: 	RECOMMENDING APPROVER: 	APPROVED BY: 	CHECKED BY: 	PROJECT TITLE:	SHEET TITLES:	SHEET NO.:
	ALL DIMENSIONS IN METERS UNLESS OTHERWISE SPECIFIED	ENGR. ANNE M. GARCIA CIVIL ENGINEER	ENGR. JUAN M. GARCIA CIVIL ENGINEER	ENGR. JUAN M. GARCIA CIVIL ENGINEER	GINA G. GARCIA UNDERSECRETARY FOR COLLEGE AND TRAINING	TEACHER'S TABLE (WOOD & STEEL)	PLAN PERSPECTIVE FRONT ELEVATION SECTION

# TEACHER'S TABLE

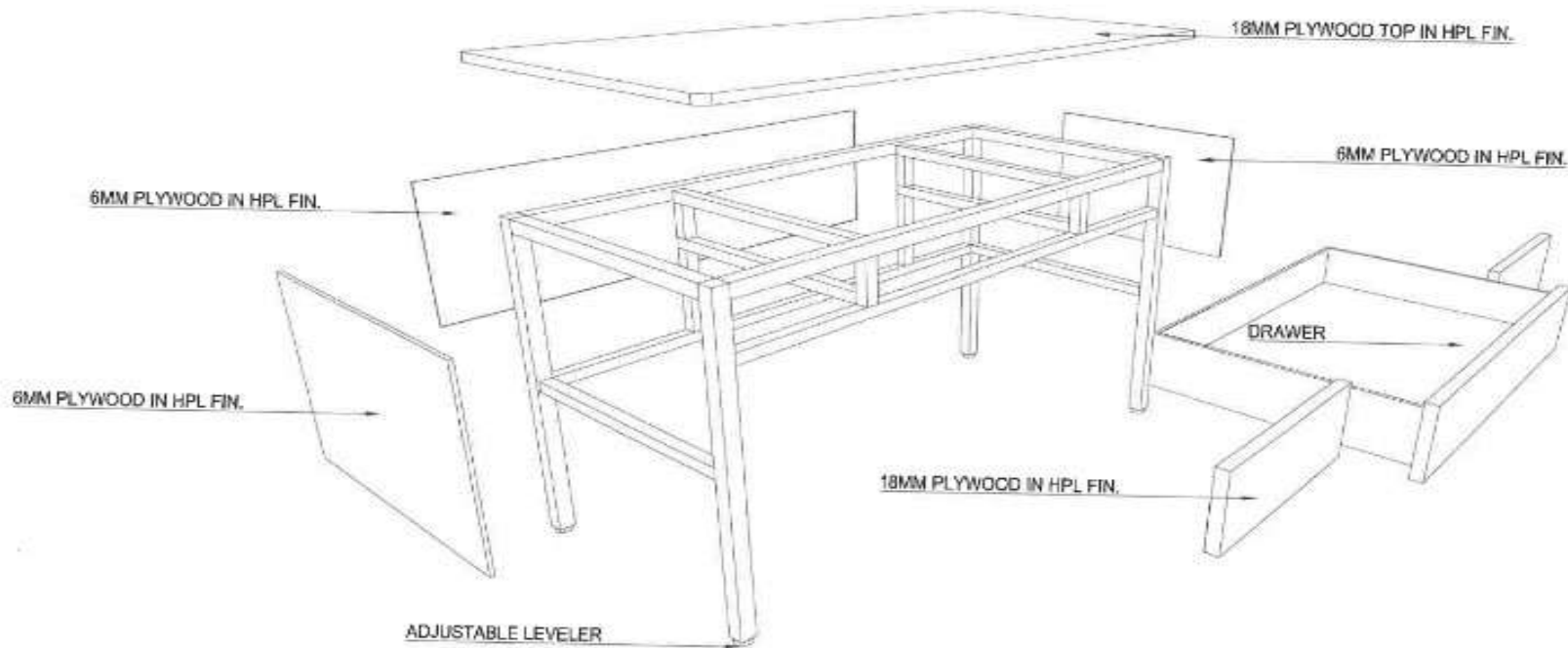

## EXPLODED VIEW

 <b>DepED</b> DEPARTMENT OF EDUCATION DIVISION OFFICE - CALABARZON MARIKINA CITY, CALABARZON	DRAWN BY:  J. ALARIDO ARCHITECT	RECOMMENDING APPROVAL:  ENGR. J. ALARIDO SHEET DESIGNER / ARCHITECT	APPROVED BY:  ENGR. J. ALARIDO UNIVERSITY OF CALABARZON CALABARZON STATE UNIVERSITY CALABARZON	CONSULTED BY:  ENGR. S. G. GARCIA UNIVERSITY OF CALABARZON CALABARZON	PROJECT TITLE: TEACHER'S TABLE (WOOD & STEEL)	SHEET CONTENTS: TEACHER'S TABLE EXPLODED VIEW	SHEET NO.: 3 5
--	---	---	---	--	---	--	----------------------



# METAL FRAMING DETAIL

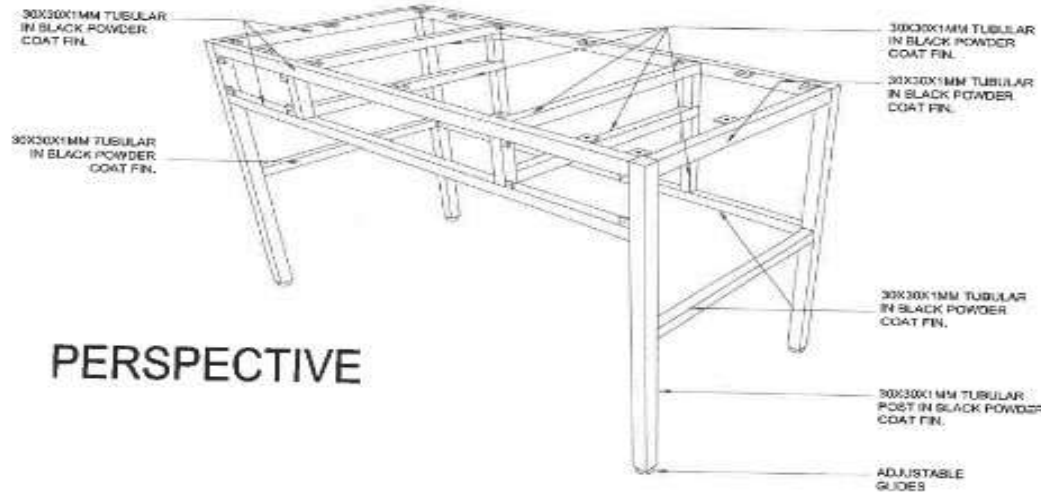

PERSPECTIVE

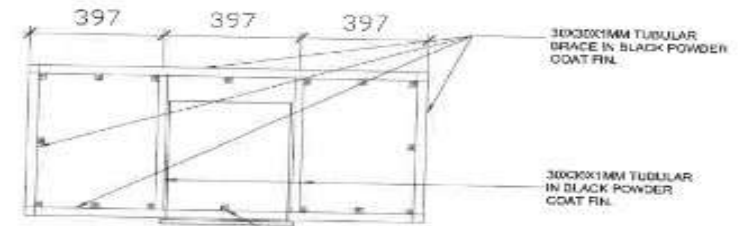

TOP

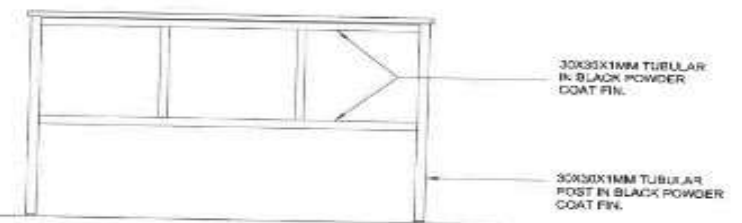

FRONT

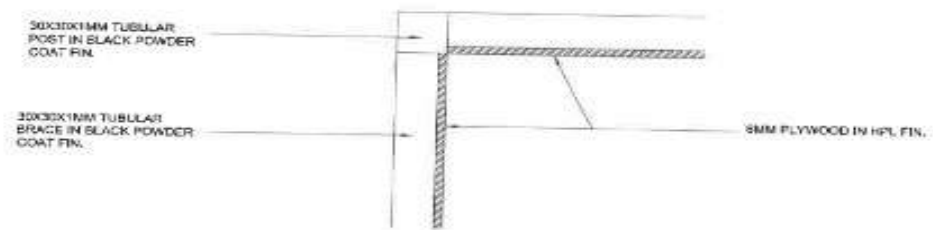

TOP VIEW SECTION

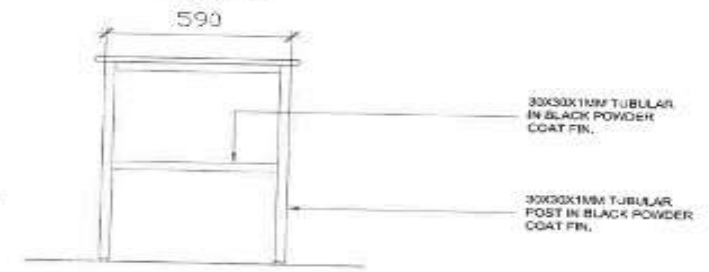

SIDE VIEW

<p>DEPARTMENT OF EDUCATION EDUCATIONAL SERVICES DIVISION MINDANAO OFFICE</p>	<p>DESIGNED BY:</p> <p><i>[Signature]</i> ARCHITECT</p>	<p>ENGINEERING APPROVAL:</p> <p><i>[Signature]</i> ENR. A. M. ALIBAS ENR - DIVISION OFFICE</p>	<p>REVISED BY:</p> <p><i>[Signature]</i> UNDERSTANDING BY: Good, Workable and Feasible</p>	<p>CHECKED BY:</p> <p><i>[Signature]</i> ENR. D. GONZA Administrative Officer and Nurse</p>	<p>PROJECT TITLE:</p> <p>TEACHER'S TABLE (WOOD &amp; STEEL)</p>	<p>SHEET DRAWING:</p> <p>METAL FRAMING PERSPECTIVE</p>	<p>SHEET NO.:</p> <p>4 5</p>
	<p>49</p>						

# METAL CENTRAL DRAWER DETAIL

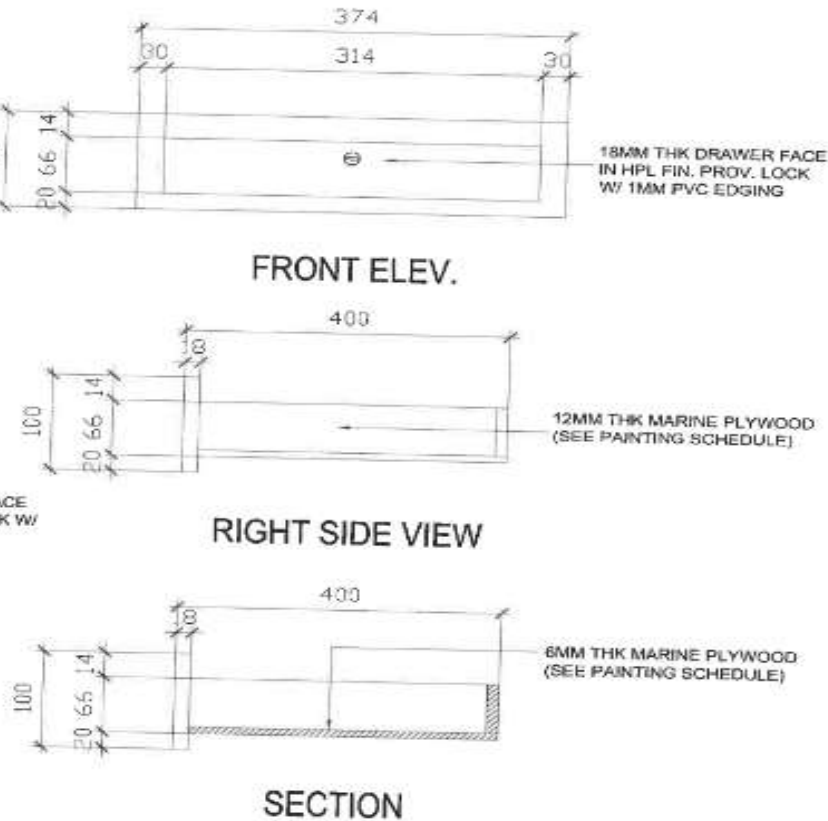
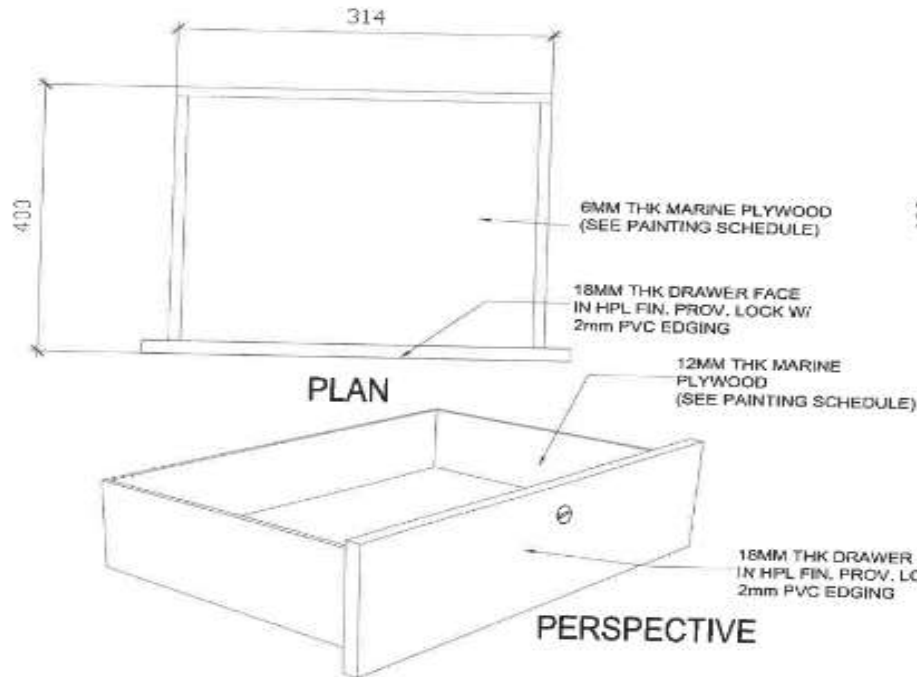

## PAINTING SCHEDULE

SANDING	ALL SURFACE TO BE COATED SHALL BE SMOOTHLY SANDED
1ST COAT	OIL WOOD STAIN - WHITE OAK FULL COLOR
INTERMEDIATE COAT	LACQUER SANDING SEALER
TOP COAT	CLEAR GLOSS LACQUER (2 COATS)

<p>DEPARTMENT OF EDUCATION                  DIVISION OFFICE - BUTUAN                  BUTUAN CITY, COMPOST VALLEY                  PHILIPPINES</p>	DESIGNED BY:  ARCHITECT	CONSULTING ARCHITECT:  CHD - BUTUAN CITY OFFICE	APPROVED BY:  SUPERVISOR FOR SPECIAL INTERVENTIONS and FACILITIES	CHECKED BY:  (MM. D. DOMINGO) SUPERVISOR FOR CURRICULUM and TEACHING	PROJECT TITLE: TEACHER'S TABLE (WOOD & STEEL)	SHEET NUMBER: METAL DRAWER DETAIL - FRONT ELEVATION SECTION EXPLODED VIEW PERSPECTIVE	SHEET NO: 5 5
--	-------------------------------	---	---	---	---	---	---------------------

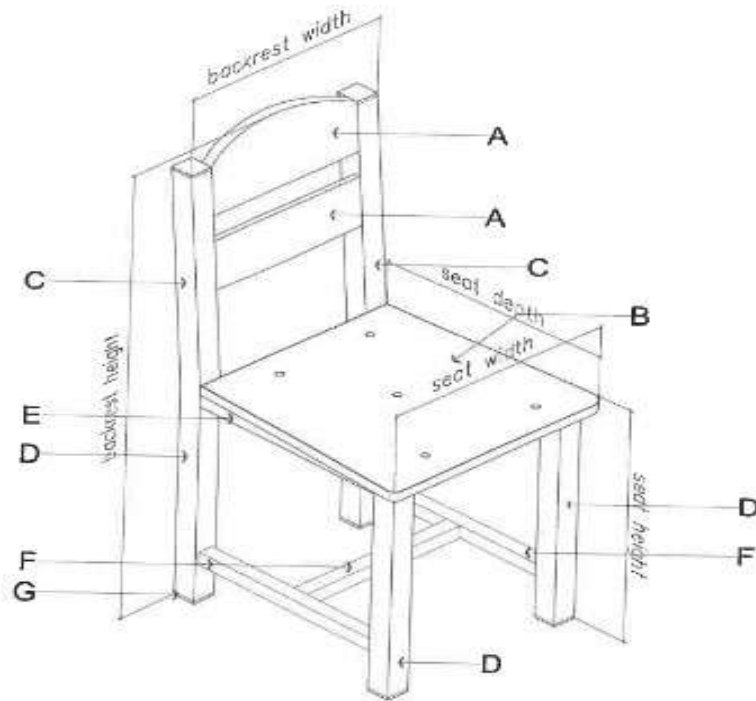

ISOMETRIC- TEACHER'S CHAIR  
SCALE 1:1

NOTES:  
WOOD GLUE SHALL BE APPLIED BEFORE INSERTING F-NUT INTO THE PLYWOOD  
CORNERS OF BACKREST & SEAT PANELS MUST BE ROUNDED

1 TECHNICAL SPECIFICATIONS OF TEACHER'S CHAIR										
MARK	COMPONENT	SPECIFICATIONS								
A	BACKREST	18mm THK BACKREST PANEL (0.9mm THK HIGH PRESSURE LAMINATE ON MARINE PLYWOOD) W/ PVC EDGING								
B	SEAT	18mm THK SEAT PANEL (0.9mm THK HIGH PRESSURE LAMINATE ON MARINE PLYWOOD) W/ PVC EDGING & 5 VENT HOLES (12mm $\phi$ )								
C	BACKREST SUPPORT	0.8mm THK x 30mm x 30mm STEEL TUBULAR								
D	LEG	0.8mm THK x 30mm x 30mm STEEL TUBULAR								
E	SEAT SUPPORT	1mm THK x 30mm x 30mm STEEL TUBULAR								
F	LEG BRACE	1mm THK x 30mm x 30mm STEEL TUBULAR								
G	FOOTING	HARD PLASTIC (BLACK)								
	EDGING	PVC EDGING								
	CONNECTION									
	WOOD TO STEEL	1mm THK x 25mm x 75mm FLAT BAR (FOR BACKREST - 1) 1mm THK x 25mm x 50mm FLAT BAR (FOR BACKREST - 2) 1mm THK x 25mm x 50mm FLAT BAR (SEAT) M6 x13mm E-NUT AND SCREW (WOOD INSERT)								
	STEEL TO STEEL	FULL WELDING - FOR TUBULAR TO TUBULAR CONNECTIONS; ADEQUATE WELDING - FOR 3/4" PIPE TO FLAT BAR CONNECTIONS								
2 SCHEDULE OF FINISHES										
BACKREST & SEAT	HIGH PRESSURE WOOD GRAIN LAMINATE W/ PVC EDGING									
METAL / STEEL	POWDER COATING (BLACK); SMOOTH, GLOSSY FINISH									
LAMINATE COLOR	SFRANO BEECH OR EQUIVALENT									
3 DIMENSIONS OF TEACHER'S CHAIR (TOLERANCE OF $\pm 10$ mm)										
COMPONENT	DIMENSIONS (mm)									
SEAT HEIGHT	440									
SEAT DEPTH	400									
SEAT WIDTH	400									
BACKREST HEIGHT	850									
BACKREST WIDTH	350									
<table border="1"> <tr> <td> </td> <td>           DESIGNED BY: <i>[Signature]</i>            PROJECT         </td> <td>           RECOMMENDING APPROVAL: <i>[Signature]</i>            EMR, DIVISION OF PLANNING            CENTER FOR EDUCATION FACILITIES DESIGN         </td> <td>           APPROVED BY: <i>[Signature]</i>            PROJECT MANAGER            Department for School Infrastructure and Facilities         </td> <td>           CHECKED BY: <i>[Signature]</i>            DIVISION ENGINEER         </td> <td>           PROJECT TITLE: <b>TEACHER'S CHAIR (WOOD &amp; STEEL)</b> </td> <td>           SHEET CONTENT: TECHNICAL SPECIFICATIONS OF TEACHER'S CHAIR            SCHEDULE OF FINISHES            DIMENSIONS            ISOMETRIC VIEW         </td> <td>           SHEET NO.: <b>1</b> <b>3</b> </td> </tr> </table>				DESIGNED BY: <i>[Signature]</i> PROJECT	RECOMMENDING APPROVAL: <i>[Signature]</i> EMR, DIVISION OF PLANNING CENTER FOR EDUCATION FACILITIES DESIGN	APPROVED BY: <i>[Signature]</i> PROJECT MANAGER Department for School Infrastructure and Facilities	CHECKED BY: <i>[Signature]</i> DIVISION ENGINEER	PROJECT TITLE: <b>TEACHER'S CHAIR (WOOD &amp; STEEL)</b>	SHEET CONTENT: TECHNICAL SPECIFICATIONS OF TEACHER'S CHAIR SCHEDULE OF FINISHES DIMENSIONS ISOMETRIC VIEW	SHEET NO.: <b>1</b> <b>3</b>
	DESIGNED BY: <i>[Signature]</i> PROJECT	RECOMMENDING APPROVAL: <i>[Signature]</i> EMR, DIVISION OF PLANNING CENTER FOR EDUCATION FACILITIES DESIGN	APPROVED BY: <i>[Signature]</i> PROJECT MANAGER Department for School Infrastructure and Facilities	CHECKED BY: <i>[Signature]</i> DIVISION ENGINEER	PROJECT TITLE: <b>TEACHER'S CHAIR (WOOD &amp; STEEL)</b>	SHEET CONTENT: TECHNICAL SPECIFICATIONS OF TEACHER'S CHAIR SCHEDULE OF FINISHES DIMENSIONS ISOMETRIC VIEW	SHEET NO.: <b>1</b> <b>3</b>			

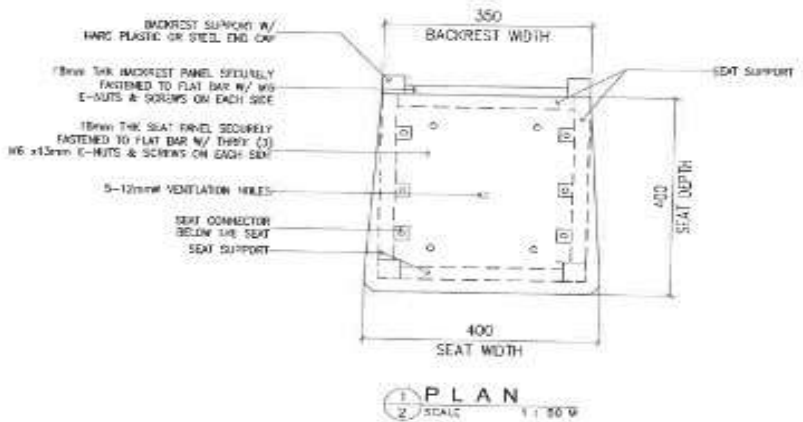

1 PLAN SCALE 1:100 M

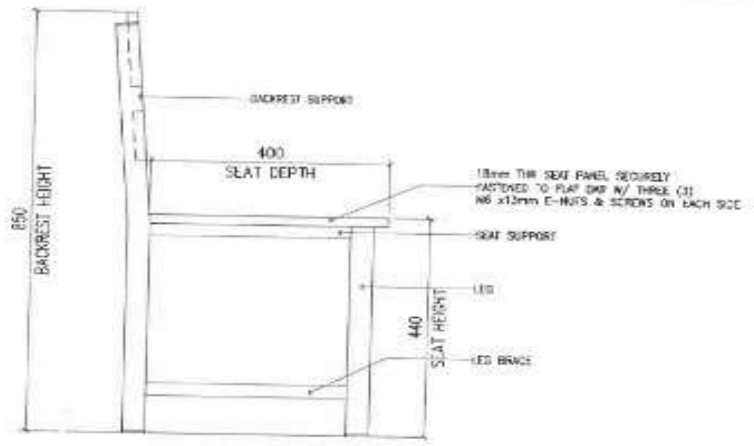

3 LEFT-SIDE ELEVATION SCALE 1:100 M

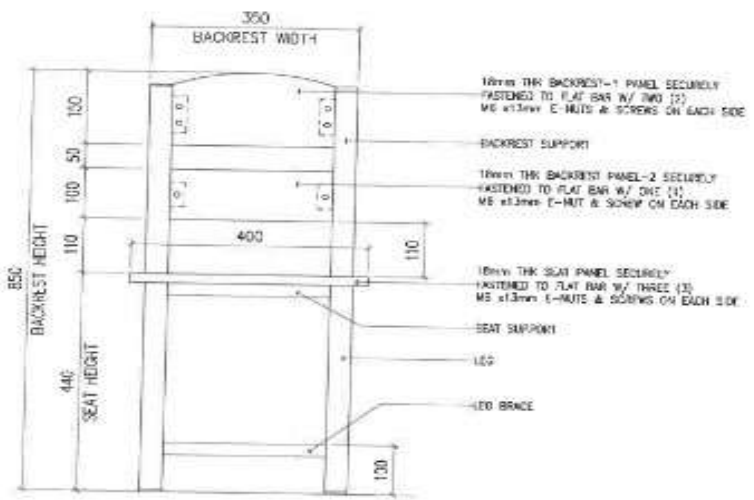

2 FRONT ELEVATION SCALE 1:100 M

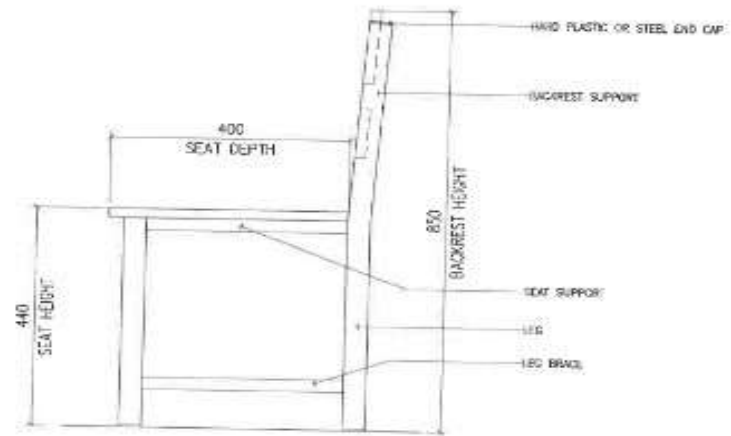

4 RIGHT-SIDE ELEVATION SCALE 1:100 M

NOTES:  
WOOD GRAIN SHALL BE APPLIED BEFORE INSERTING E-NUT INTO THE PLYWOOD CORNERS OF BACKREST & SEAT PANELS MUST BE ROUNDED

<p>DEPARTMENT OF EDUCATION EDUCATION DIVISION BUREAU OF TECHNICAL EDUCATION MANILA OFFICE, PASAY CITY</p>	<p>DESIGNED BY: <i>[Signature]</i> JET ANTONIO T. ROSALES 480-1101</p>	<p>RECOMMENDING APPROVAL: <i>[Signature]</i> ENGR. MARCO V. DENING CHIEF - TECHNICAL DIVISION (TDC)</p>	<p>APPROVED BY: <i>[Signature]</i> ENRICO V. DENING III Chairman of School Technical Education Committee</p>	<p>DESIGNED BY: <i>[Signature]</i> GEM D. GARDINO Undersecretary for Curriculum and Learning</p>	<p>PROJECT TITLE: <b>TEACHER'S CHAIR (WOOD &amp; STEEL)</b></p>	<p>DRAWN BY: PAKS &amp; GLENDA - TACEDS-DIV</p>	<p>SHEET NO. 2 3</p>
	<p>TEACHER'S CHAIR (WOOD &amp; STEEL)</p>						



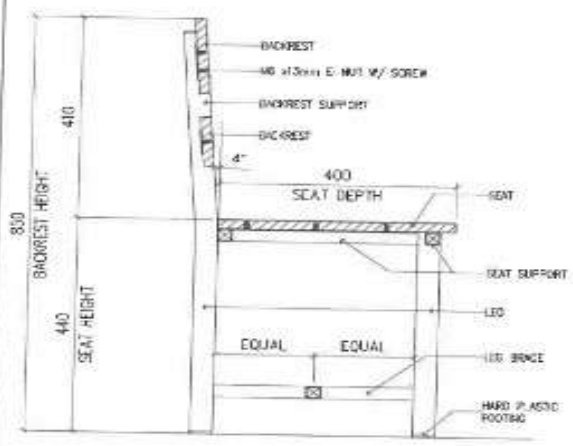

1 CROSS SECTION  
3 SCALE 1:50 M

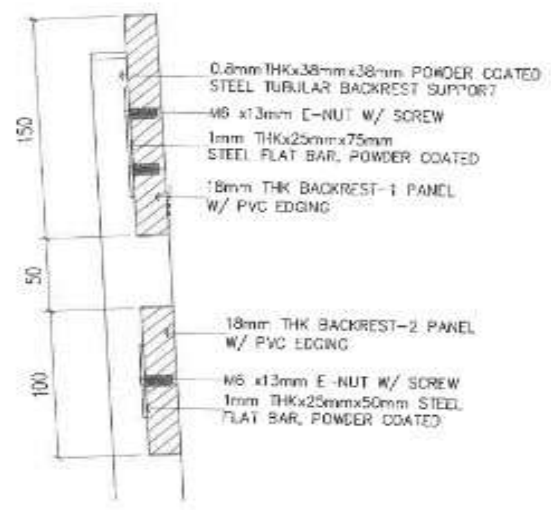

3 DETAIL - 1  
3 SCALE 1:50 M

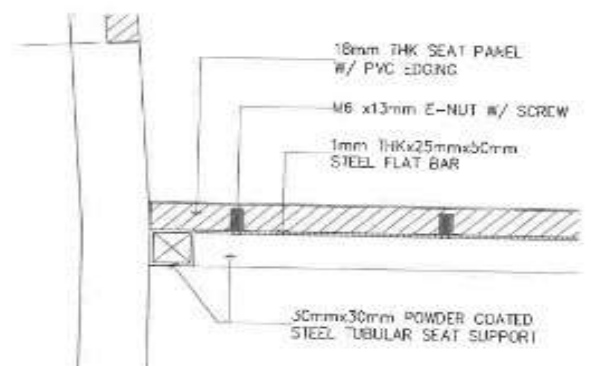

4 DETAIL - 2  
3 SCALE 1:50 M

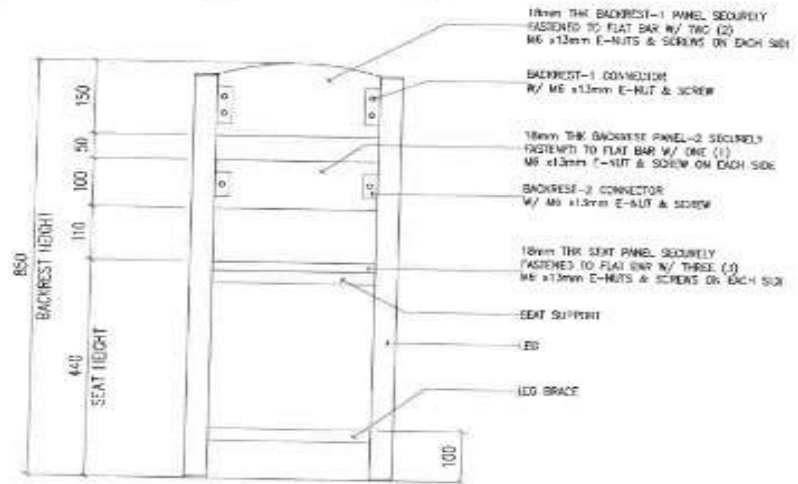

2 REAR ELEVATION  
3 SCALE 1:50 M

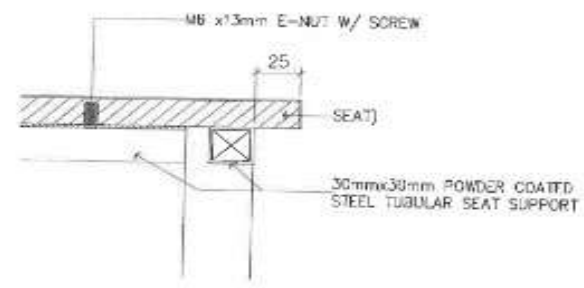

5 DETAIL - 3  
3 SCALE 1:50 M

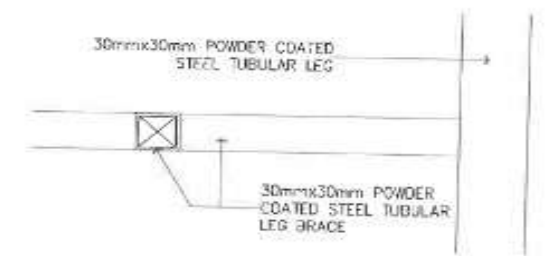

6 DETAIL - 4  
3 SCALE 1:50 M

NOTES:  
1. RICKER GLUE SHALL BE APPLIED BEFORE INSERTING E-NUT INTO THE PLUNGED CORNERS ON BACKREST & SEAT PANELS MUST BE FOUNDED

	DESIGN BY	ARCHITECTURAL APPROVAL	APPROVED BY	ENGINEER BY	PROJECT TITLE	SHEET CONTENTS	SHEET NO.
	 MARCO D. FLANCO ARCHITECT	 DIV. OFFICIAL CHD - REGIONAL OFFICE OF DENR	 DIV. OFFICIAL CHD - REGIONAL OFFICE OF DENR	 DIV. OFFICIAL CHD - REGIONAL OFFICE OF DENR	TEACHER'S CHAIR (WOOD & STEEL)	CROSS SECTION REAR ELEVATION SEAT DETAILS	3 3

## **DEPED LOGO SPECIFICATIONS FOR ALL LEARNER AND TEACHER'S CHAIR**

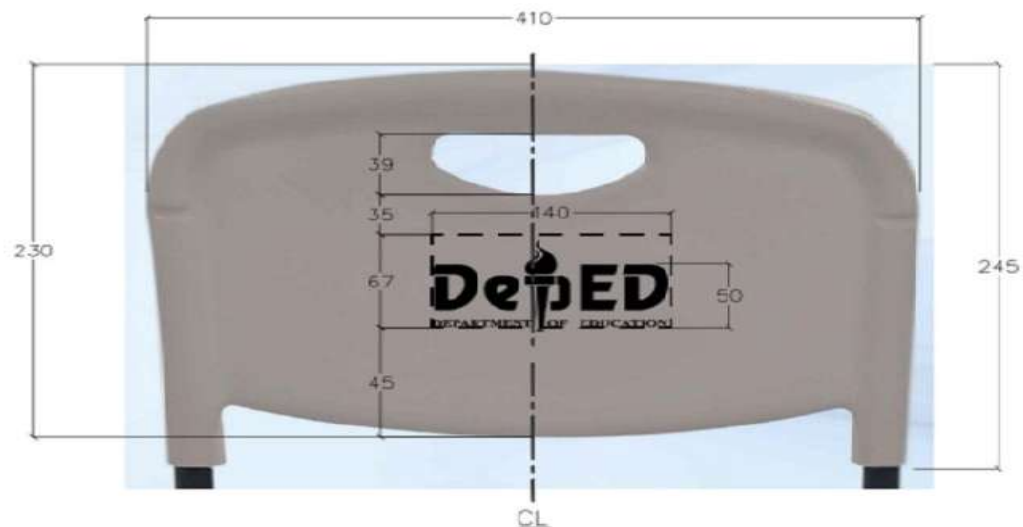

HDPE BACK DEPED LOGO DETAIL



DEPED LOGO



PERSPECTIVE VIEW

### SPECIFICATIONS:

1. MATERIAL: BLOW MOLDED HDPE.
  2. MARKINGS: MINIMUM OF 0.8MM DEPTH EMBOSSED / MOLDED OFFICIAL "DepEd LOGO" WITH THE INSCRIPTION "DEPARTMENT OF EDUCATION" AS PER DRAWING.
  3. COLOR CODE: PANTONE 4665C OR COLOR HEX: #cda788 / RGB: 205, 167, 136 / CMYK: 0%, 19%, 34%, 20%
  4. DEPED LOGO COLOR IS THE SAME AS BACKREST COLOR CODE.
- NOTE: BLACK COLOR OF LOGO SHOWN IS FOR ILLUSTRATION ONLY.

ANNEX B – List of Recipient Schools

**CY 2024 BASIC EDUCATIONAL FACILITIES FUND**

**PROVISION OF SCHOOL FURNITURE - 75% Allocation for Regular Suppliers**

**IMPLEMENTING OFFICE: REGIONAL OFFICE**

**LOT 1**

LIST OF RECIPIENT SCHOOLS									
Region	Division	School ID	School Name	Municipality	No. of Sites	Elem. Individual Learner Table & Chair Set	JHS Individual Learner Table & Chair Set	SHS Individual Learner Table & Chair Set	Teacher's Table & Chair Set
CAR	Apayao	501756	CADACLAN INTEGRATED SCHOOL	CALANASAN (BAYAG)	1			240	6
CAR	Benguet	501757	Lam-ayan Integrated School	BUGUIAS	1			160	4
CAR	Benguet	135517	Balatoc Elementary School	ITOGON	1	405			9
CAR	Benguet	305126	Ampucao National High School	ITOGON	1		135		3
CAR	Benguet	305539	AMBIONG NATIONAL HIGH SCHOOL	LA TRINIDAD (Capital)	1		90		2
CAR	Benguet	135669	Taneg ES	MANKAYAN	1	225			5
CAR	Benguet	502168	Mogao Integrated School	MANKAYAN	1	90		200	7
CAR	Benguet	135693	Indaoac ES	TUBA	1	45			1
CAR	Benguet	318904	Tuba Central NHS	TUBA	1		405		10
CAR	Benguet	305164	Tublay National Trade High School	TUBLAY	1		225		5
CAR	Benguet	135623	Buyagan Es	LA TRINIDAD (Capital)	1	935			21
CAR	Benguet	135635	Wangal ES	LA TRINIDAD (Capital)	1	135			3
CAR	Benguet	135428	Ambuklao ES	BOKOD	1	90			2
CAR	Benguet	135554	Kabayan Central School	KABAYAN	1	270			6
CAR	Benguet	135583	Pudong ES	KAPANGAN	1	90			2

CAR	Benguet	318909	Eastern La Trinidad NHS	LA TRINIDAD (Capital)	1		495		11
CAR	Benguet	135395	Pasdong ES	ATOK	1	90			2
CAR	Benguet	135634	Tawang ES		1	225			5
CAR	Ifugao	135741	Awayan ES	AGUINALDO	1	180			4
CAR	Ifugao	135819	Cambulo ES - Mattao Annex	BANAUE	1	45			1
CAR	Ifugao	305182	Kiangan NHS	KIANGAN	1		270		6
CAR	Ifugao	135879	Banga ES	LAGAWE (Capital)	1	45			1
CAR	Ifugao	135880	Boliwong ES	LAGAWE (Capital)	1	90			2
CAR	Ifugao	135884	Cudog ES	LAGAWE (Capital)	1	135			3
CAR	Ifugao	135888	Luta PS	LAGAWE (Capital)	1	45			1
CAR	Ifugao	220020	Ifugao SPED Center	LAGAWE (Capital)	1	225			5
CAR	Ifugao	305169	Caba National High School	LAGAWE (Capital)	1		180		4
CAR	Ifugao	319004	Lagawe NHS	LAGAWE (Capital)	1		270		6
CAR	Ifugao	135898	Dunuan ES	LAMUT	1	225			5
CAR	Ifugao	135910	Pieza ES	LAMUT	1	90			2
CAR	Ifugao	135912	Pulaan PS	LAMUT	1	45			1
CAR	Ifugao	305176	Hapid NHS	LAMUT	1		180		4
CAR	Ifugao	305177	Ifugao Technical Vocational School	LAMUT	1		540		12
CAR	Ifugao	305181	Ifugao Prov'l. Science HS	LAMUT	1		360		8
CAR	Ifugao	305183	Lawig NHS (Main)	LAMUT	1		180		4
CAR	Ifugao	500882	Alupapan Integrated School	LAMUT	1	135		240	9
CAR	Ifugao	135922	Buninan PS	MAYOYAO	1	45			1
CAR	Ifugao	135936	Nattum PS (Abagong)	MAYOYAO	1	45			1
CAR	Ifugao	135940	Tulaed ES	MAYOYAO	1	135			3
CAR	Ifugao	305185	Mayoyao NHS	MAYOYAO	1		45		1
CAR	Ifugao	305186	Tulaed NHS	MAYOYAO	1		180		4
CAR	Ifugao	135945	Danggo ES	TINOC	1	135			3
CAR	Ifugao	135947	Gumhang Elementary School	TINOC	1	315			7
CAR	Ifugao	305192	Tinoc NHS	TINOC	1		540		12



CAR	Ifugao	135760	Alfonso Lista CS	ALFONSO LISTA	1	990			22
CAR	Ifugao	135740	Aguinaldo CS	AGUINALDO	1	225			5
CAR	Ifugao	135902	Lamut CS	LAMUT	1	585			13
CAR	Ifugao	135758	Monggayang ES		1	225			5
CAR	Ifugao	135776	Namilliangan ES		1	315			7
CAR	Ifugao	305187	Namilliangan NHS		1		315		7
CAR	Ifugao	135907	Nayun ES		1	270			6
CAR	Ifugao	135841	O-ong ES		1	180			4
CAR	Ifugao	135760	Pojnaan ES		1	270			6
CAR	Ifugao	135915	Sanafe ES		1	225			5
CAR	Ifugao	135782	San Juan ES		1	135			3
CAR	Ifugao	135828	San Fernando ES		1	45			1
CAR	Kalinga	135970	Bullalayao Primary School	BALBALAN	1	45			1
CAR	Kalinga	305227	Western Kalinga National High School	BALBALAN	1		90		2
CAR	Kalinga	306053	Eastern Balbalan National High School	BALBALAN	1		90		2
CAR	Kalinga	319116	Balbalan National High school	BALBALAN	1		90		2
CAR	Kalinga	135989	Dangoy Elementary School	LUBUAGAN	1	225			5
CAR	Kalinga	135993	Mabilong Elementary School	LUBUAGAN	1	180			4
CAR	Kalinga	340131	SHS in Lubuagan, Kalinga	LUBUAGAN	1		90		2
CAR	Kalinga	136049	Malaap Elementary School	PINUKPUK	1	45			1
CAR	Kalinga	305202	Cawagayan National High School	PINUKPUK	1		360		8
CAR	Kalinga	305210	Limos National High School - Dao-angan Extension	PINUKPUK	1		225		5
CAR	Kalinga	305542	Malagnat National High School-Taggay Extension	PINUKPUK	1		405		9
CAR	Kalinga	319107	Camalog National High School-Pinococ Extension	PINUKPUK	1		225		5
CAR	Kalinga	319107	Camalog National High School	PINUKPUK	1		270		6
CAR	Kalinga	NOT-IN-NSBI	Malagnat NHS	PINUKPUK	1		270	160	13

CAR	Kalinga	136071	Kinama Elementary School	RIZAL (LIWAN)	1	405			9
CAR	Kalinga	136076	Rizal Central School	RIZAL (LIWAN)	1	540			12
CAR	Kalinga	305218	Macutay Palao National High School	RIZAL (LIWAN)	1		405		9
CAR	Kalinga	NOT-IN-NSBI	Bagbag Elementary School Bulbul Annex	RIZAL (LIWAN)	1	180			4
CAR	Kalinga	NOT-IN-NSBI	Rizal Central School Cadao Annex	RIZAL (LIWAN)	1	120			3
CAR	Kalinga	NOT-IN-NSBI	Santor NHS	RIZAL (LIWAN)	1		160	160	5
CAR	Kalinga	136123	Dacalan Elementary School	TANUDAN	1	45			1
CAR	Kalinga	136126	Lubo Elementary School	TANUDAN	1	90			2
CAR	Kalinga	136143	Ambato-Legleg Elementary School	TINGLAYAN	1	90			2
CAR	Mt. Province	136186	Kadaclan Elementary School	BARLIG	1	90			2
CAR	Mt. Province	136233	Ambagiw ES	BESAO	1	45			1
CAR	Mt. Province	136239	Dandanac Elementary School	BESAO	1	45			1
CAR	Mt. Province	136248	Tambuan Elementary School	BESAO	1	90			2
CAR	Mt. Province	221006	Mountain Province SPED Center	BONTOC (Capital)	1	270			6
CAR	Mt. Province	305924	Mainit National High School	BONTOC (Capital)	1		90		2
CAR	Mt. Province	305258	Natonin National High School	NATONIN	1		315		7
CAR	Mt. Province	319203	Saliok National High School	NATONIN	1		180		4
CAR	Mt. Province	136289	Butigue Elementary School	PARACELIS	1	315			7
CAR	Mt. Province	136307	Mulliang Elementary School	PARACELIS	1	135			3

CAR	Mt. Province	136310	Paracelis Central School	PARACELIS	1	675			15
CAR	Mt. Province	305231	Paracelis Technical & Vocational High School	PARACELIS	1		90		2
CAR	Mt. Province	319202	San Rafael National High School	PARACELIS	1		180		4
CAR	Mt. Province	319220	Anonat National Agricultural and Vocational High School	PARACELIS	1		135		3
CAR	Mt. Province	136350	Payag-eo Elementary School	SAGADA	1	90			2
CAR	Mt. Province	305266	Ankileng National High School	SAGADA	1		135		3
CAR	Mt. Province	136372	Masla Elementary School	TADIAN	1	135			3
CAR	Mt. Province	136376	Tadian Central School	TADIAN	1	270			6
CAR	Mt. Province	319221	Balaoa National High School	TADIAN	1		45		1
CAR	Mt. Province	136185	Barlig CS	BARLIG	1	135			3
CAR	Mt. Province	305235	Barlig NHS	BARLIG	1	135			3
CAR	Mt. Province	136234	Banguitan ES	BESAO	1	135			3
CAR	Mt. Province	136237	Bunga ES	BESAO	1	45			1
CAR	Mt. Province	305237	Besao NHS	BESAO	1		270		6
CAR	Mt. Province	305268	Talubin NHS	BONTOC (Capital)	1		90		2
CAR	Mt. Province	319216	Banawen NHS	NATONIN	1		135		3

CAR	Mt. Province	1363078	Natta'llongan ES	PARACELIS	1	180			4
CAR	Mt. Province	36310	Paracellis CS	PARACELIS	1	720			16
CAR	Mt. Province	305262	Pingad NHS	SABANGAN	1		495		11
CAR	Mt. Province	305234	Banga-an NHS	SAGADA	1		90		2
CAR	Mt. Province	136348	Kilong ES	SAGADA	1	45			1
CAR	Tabuk City	136086	Bulanao Central School	CITY OF TABUK (Capital)	1	1170			30
CAR	Tabuk City	136093	Calaccad Elementary School	CITY OF TABUK (Capital)	1	90			2
CAR	Tabuk City	136153	Addang Primary School	CITY OF TABUK (Capital)	1	45			1
CAR	Tabuk City	136158	Balawag Elementary School	CITY OF TABUK (Capital)	1	45			1
CAR	Tabuk City	136183	Western Tabuk CS	CITY OF TABUK (Capital)	1	270			6
CAR	Tabuk City	220529	San Pablo Primary School	CITY OF TABUK (Capital)	1	270			6
CAR	Tabuk City	220531	Bulanao East Annex - Greenhills PS	CITY OF TABUK (Capital)	1	450			10
CAR	Tabuk City	305200	Calaccad National High School	CITY OF TABUK (Capital)	1		135		3
CAR	Tabuk City	319101	Bulo National High School	CITY OF TABUK (Capital)	1		180		4
CAR	Tabuk City	501889	Toppan Integrated School	CITY OF TABUK (Capital)	1		90		2
CAR	Tabuk City	501889	Toppan Integrated School	CITY OF TABUK (Capital)	1		180		4

CAR	Tabuk City	501890	MALEDDA INTEGRATED SCHOOL	CITY OF TABUK (Capital)	1		225		5
CAR	Tabuk City	502123	Guilayon Integrated School	CITY OF TABUK (Capital)	1	45	45		2
CAR	Tabuk City	502380	Appas Integrated School	CITY OF TABUK (Capital)	1	45	45		2
CAR	Tabuk City	NOT-IN-NSBI	Tabuk City National High School - BANTAY EXT.	CITY OF TABUK (Capital)	1		450	200	15
<b>CAR Total</b>					<b>125</b>	<b>15,950</b>	<b>10,690</b>	<b>1,360</b>	<b>632</b>

**CY 2024 BASIC EDUCATIONAL FACILITIES FUND**  
**PROVISION OF SCHOOL FURNITURE - 15% Allocation for Regular Cooperative**  
**IMPLEMENTING OFFICE: REGIONAL OFFICE**

**LOT 2**

**LIST OF RECIPIENT SCHOOLS**

Region	Division	School ID	School Name	Municipality	No. of Sites	Elem. Individual Learner Table & Chair Set	JHS Individual Learner Table & Chair Set	SHS Individual Learner Table & Chair Set	Teacher's Table & Chair Set
CAR	Abra	134994	Dugong ES	BUWAY	1	225			5
CAR	Abra	135027	Benben Elementary School	LA PAZ	1	90			2
CAR	Abra	318701	MARC YSRAEL B. BERNOS MEMORIAL NATIONAL HIGH SCHOOL	LA PAZ	1		360		8
CAR	Abra	500743	La Paz Integrated School	LA PAZ	1			465	10
CAR	Abra		El Bernos Elementary School	LA PAZ	1	180			4
CAR	Abra	305087	Langiden NHS	LANGIDEN	1		180		4
CAR	Abra	305098	Manabo NHS (San Jose Catacdegan NHS)	MANABO	1		270		6
CAR	Abra	500590	Peñarrubia Integrated School	PEÑARRUBIA	1		270	320	15
CAR	Abra	305093	Pilar Rural High School	PILAR	1		180		4
CAR	Abra	500518	An-anao Integrated School	TAYUM	1	45		320	9
CAR	Abra	135028	Bulbulala ES	LA PAZ	1	90			2
CAR	Abra	135029	Canan ES	LA PAZ	1	45			1
CAR	Abra	135034	Liguís ES	LA PAZ	1	45			1
CAR	Abra	135035	Malabbaga ES	LA PAZ	1	90			2
CAR	Apayao	135280	Talifugo ES	CONNER	1	45			1
CAR	Apayao	305111	Conner Central NHS Main	CONNER	1		585		13
CAR	Apayao	502117	San Jose Integrated School	FLORA	1			80	2

CAR	Apayao	135298	Baliwanan ES	KABUGAO (Capital)	1	45			1
CAR	Apayao	135347	Sta. Lina ES	LUNA	1	90			2
CAR	Apayao	135306	Apadi ES	KABUGAO (Capital)	1	45			1
CAR	Apayao	135319	Madatag ES	KABUGAO (Capital)	1	90			2
CAR	Baguio City	136380	Adiwang Elementary School	BAGUIO CITY	1	135			3
CAR	Baguio City	136382	Baguio Central school	BAGUIO CITY	1	360			8
CAR	Benguet	305158	Sinipsip National High School	BUGUIAS	1		360		8
CAR	Benguet	135562	Balakbak ES	KAPANGAN	1	225			5
CAR	Benguet	135631	Puguis Elementary School	LA TRINIDAD (Capital)	1	315			7
<b>CAR Total</b>					<b>26</b>	<b>2,160</b>	<b>2,205</b>	<b>1,185</b>	<b>126</b>

***Section VIII. Checklist of Technical and  
Financial Documents***



# Checklist of Technical and Financial Documents

## I. TECHNICAL COMPONENT ENVELOPE

### *Class "A" Documents*

#### Legal Documents

- (a) Valid PhilGEPS Registration Certificate (Platinum Membership) (all pages) **in accordance with Section 8.5.2 of the IRR;**

#### Technical Documents

- (b) Statement of the prospective bidder of all its ongoing government and private contracts, including contracts awarded but not yet started, if any, whether similar or not similar in nature and complexity to the contract to be bid; **and**
- (c) Statement of the bidder's Single Largest Completed Contract (SLCC) similar to the contract to be bid, except under conditions provided for in Sections 23.4.1.3 and 23.4.2.4 of the 2016 revised IRR of RA No. 9184, within the relevant period as provided in the Bidding Documents; **and**
- (d) Original copy of Bid Security. If in the form of a Surety Bond, submit also a certification issued by the Insurance Commission;  
**or**  
Original copy of Notarized Bid Securing Declaration; **and**
- (e) Conformity with the Technical Specifications, which may include production/delivery schedule, manpower requirements, and/or after-sales/parts, if applicable; **and**
- (f) Original duly signed (Revised: 10 items) Omnibus Sworn Statement (OSS); **and** if applicable, Original Notarized Secretary's Certificate in case of a corporation, partnership, or cooperative; or Original Special Power of Attorney of all members of the joint venture giving full power and authority to its officer to sign the OSS and do acts to represent the Bidder.

#### Financial Documents

- (g) The prospective bidder's computation of Net Financial Contracting Capacity (NFCC);  
**or**  
A committed Line of Credit from a Universal or Commercial Bank in lieu of its NFCC computation.

### *Class "B" Documents*

- (h) If applicable, a duly signed joint venture agreement (JVA) in case the joint venture is already in existence;  
**or**  
duly notarized statements from all the potential joint venture partners stating that they will enter into and abide by the provisions of the JVA in the instance that the bid is successful.

#### Other documentary requirements under RA No. 9184 (as applicable)

- (i) *[For foreign bidders claiming by reason of their country's extension of reciprocal rights to Filipinos]* Certification from the relevant government office of their country stating that Filipinos are allowed to participate in government procurement activities for the same item or product.

- (j) Certification from the DTI if the Bidder claims preference as a Domestic Bidder or Domestic Entity.

**25 FINANCIAL COMPONENT ENVELOPE**

- (a) Original of duly signed and accomplished Financial Bid Form; **and**  
 (b) Original of duly signed and accomplished Price Schedule(s).

*Note: Templates for the Omnibus Sworn Statement (Revised), Bid Form and the Bid Securing Declaration, Price Schedule for Goods offered within the Philippines, the Price Schedule for Goods Offered from Abroad are herein attached, Single Largest Completed Contract, Statement of On-going Projects and*

## List of all Ongoing Government & Private Contracts including contracts awarded but not yet started

Business Name : \_\_\_\_\_

Business Address : \_\_\_\_\_

Name of Contract	Date of Contract	a. Owner's Name b. Address c. Telephone Nos.	Contract Duration	Date of Delivery	Kinds of Goods	Amount of Contract	Value of Outstanding Contracts
<b>GOVERNMENT</b>							
<b>PRIVATE</b>							

Note:

State all ongoing contracts including contracts awarded but not yet started, if any, whether similar or not similar in nature and complexity to the contract to be bid. Statement must be supported by a copy of the following:

1. Notice of Award or Contract
2. Notice to Proceed issued by the owner (*in the absence of Notice to Proceed (NTP), execute an affidavit that the bidder asserted all efforts in requesting the NTP. Indicate the circumstances and state the reasons. Attach letter of request as supporting documents*).

Submitted by: \_\_\_\_\_

(Printed Name and Signature)

Designation : \_\_\_\_\_

Date : \_\_\_\_\_

*NOTE: Use another sheet if necessary*

**Statement of Single Largest Completed Contract (SLCC) Similar  
to the Contract to be Bid**

Business Name : \_\_\_\_\_

Business Address : \_\_\_\_\_

Name of Contract	Date of Contract	a. Owner's Name b. Address c. TelephoneNos.	Contract Duration	Date of Delivery	Kinds of Goods	Amount of Completed Contract

Note: This statement shall be supported with:

1. Certificate of End-users Acceptance or Official Receipt/s or Sales Invoice.

Submitted by : \_\_\_\_\_  
(Printed Name and Signature)

Designation : \_\_\_\_\_

Date : \_\_\_\_\_

## Omnibus Sworn Statement (Revised)

*[shall be submitted with the Bid]*

REPUBLIC OF THE PHILIPPINES )  
CITY/MUNICIPALITY OF \_\_\_\_\_ ) S.S.

### AFFIDAVIT

I, [Name of Affiant], of legal age, [Civil Status], [Nationality], and residing at [Address of Affiant], after having been duly sworn in accordance with law, do hereby depose and state that:

1. *[Select one, delete the other:]*

*[If a sole proprietorship:]* I am the sole proprietor or authorized representative of [Name of Bidder] with office address at [address of Bidder];

*[If a partnership, corporation, cooperative, or joint venture:]* I am the duly authorized and designated representative of [Name of Bidder] with office address at [address of Bidder];

2. *[Select one, delete the other:]*

*[If a sole proprietorship:]* As the owner and sole proprietor, or authorized representative of [Name of Bidder], I have full power and authority to do, execute and perform any and all acts necessary to participate, submit the bid, and to sign and execute the ensuing contract for [Name of the Project] of the [Name of the Procuring Entity], as shown in the attached duly notarized Special Power of Attorney;

*[If a partnership, corporation, cooperative, or joint venture:]* I am granted full power and authority to do, execute and perform any and all acts necessary to participate, submit the bid, and to sign and execute the ensuing contract for [Name of the Project] of the [Name of the Procuring Entity], as shown in the attached [state title of attached document showing proof of authorization (e.g., duly notarized Secretary's Certificate, Board/Partnership Resolution, or Special Power of Attorney, whichever is applicable)];

3. [Name of Bidder] is not "blacklisted" or barred from bidding by the Government of the Philippines or any of its agencies, offices, corporations, or Local Government Units, foreign government/foreign or international financing institution whose blacklisting rules have been recognized by the Government Procurement Policy Board, **by itself or by relation, membership, association, affiliation, or controlling interest with another blacklisted person or entity as defined and provided for in the Uniform Guidelines on Blacklisting;**

4. Each of the documents submitted in satisfaction of the bidding requirements is an authentic copy of the original, complete, and all statements and information provided therein are true and correct;

5. [Name of Bidder] is authorizing the Head of the Procuring Entity or its duly authorized representative(s) to verify all the documents submitted;

6. *[Select one, delete the rest:]*

*[If a sole proprietorship:]* The owner or sole proprietor is not related to the Head of the Procuring Entity, members of the Bids and Awards Committee (BAC), the Technical Working Group, and the BAC Secretariat, the head of the Project Management Office or the end-user unit, and the project consultants by consanguinity or affinity up to the third civil degree;

*[If a partnership or cooperative:]* None of the officers and members of *[Name of Bidder]* is related to the Head of the Procuring Entity, members of the Bids and Awards Committee (BAC), the Technical Working Group, and the BAC Secretariat, the head of the Project Management Office or the end-user unit, and the project consultants by consanguinity or affinity up to the third civil degree;

*[If a corporation or joint venture:]* None of the officers, directors, and controlling stockholders of *[Name of Bidder]* is related to the Head of the Procuring Entity, members of the Bids and Awards Committee (BAC), the Technical Working Group, and the BAC Secretariat, the head of the Project Management Office or the end-user unit, and the project consultants by consanguinity or affinity up to the third civil degree;

7. *[Name of Bidder]* complies with existing labor laws and standards; and
8. *[Name of Bidder]* is aware of and has undertaken the responsibilities as a Bidder in compliance with the Philippine Bidding Documents, which includes:
  - a. Carefully examining all of the Bidding Documents;
  - b. Acknowledging all conditions, local or otherwise, affecting the implementation of the Contract;
  - c. Making an estimate of the facilities available and needed for the contract to be bid, if any; and
  - d. Inquiring or securing Supplemental/Bid Bulletin(s) issued for the *[Name of the Project]*.
9. *[Name of Bidder]* did not give or pay directly or indirectly, any commission, amount, fee, or any form of consideration, pecuniary or otherwise, to any person or official, personnel or representative of the government in relation to any procurement project or activity.
10. **In case advance payment was made or given, failure to perform or deliver any of the obligations and undertakings in the contract shall be sufficient grounds to constitute criminal liability for Swindling (Estafa) or the commission of fraud with unfaithfulness or abuse of confidence through misappropriating or converting any payment received by a person or entity under an obligation involving the duty to deliver certain goods or services, to the prejudice of the public and the government of the Philippines pursuant to Article 315 of Act No. 3815 s. 1930, as amended, or the Revised Penal Code.**

IN WITNESS WHEREOF, I have hereunto set my hand this \_\_\_ day of \_\_\_, 20\_\_ at \_\_\_\_\_, Philippines.

*[Insert NAME OF BIDDER OR ITS AUTHORIZED REPRESENTATIVE]*

*[Insert signatory's legal capacity]*

Affiant

**[Jurat]**

*[Format shall be based on the latest Rules on Notarial Practice]*

**Bid Form for the Procurement of Goods**  
*[shall be submitted with the Bid]*

---

**BID FORM**

Date : \_\_\_\_\_  
 Project Identification No. : \_\_\_\_\_

To: *[name and address of Procuring Entity]*

Having examined the Philippine Bidding Documents (PBDs) including the Supplemental or Bid Bulletin Numbers *[insert numbers]*, the receipt of which is hereby duly acknowledged, we, the undersigned, offer to *[supply/deliver/perform]* *[description of the Goods]* in conformity with the said PBDs for the sum of *[total Bid amount in words and figures]* or the total calculated bid price, as evaluated and corrected for computational errors, and other bid modifications in accordance with the Price Schedules attached herewith and made part of this Bid. The total bid price includes the cost of all taxes, such as, but not limited to: *[specify the applicable taxes, e.g. (i) value added tax (VAT), (ii) income tax, (iii) local taxes, and (iv) other fiscal levies and duties]*, which are itemized herein or in the Price Schedules,

If our Bid is accepted, we undertake:

- a. to deliver the goods in accordance with the delivery schedule specified in the Schedule of Requirements of the Philippine Bidding Documents (PBDs);
- b. to provide a performance security in the form, amounts, and within the times prescribed in the PBDs;
- c. to abide by the Bid Validity Period specified in the PBDs and it shall remain binding upon us at any time before the expiration of that period.

*[Insert this paragraph if Foreign-Assisted Project with the Development Partner:*

Commissions or gratuities, if any, paid or to be paid by us to agents relating to this Bid, and to contract execution if we are awarded the contract, are listed below:

Name and address of agent	Amount	Purpose of Commission or gratuity
---------------------------	--------	-----------------------------------

*(if none, state “None”)* ]

Until a formal Contract is prepared and executed, this Bid, together with your written acceptance thereof and your Notice of Award, shall be binding upon us.

We understand that you are not bound to accept the Lowest Calculated Bid or any Bid you may receive.

We certify/confirm that we comply with the eligibility requirements pursuant to the PBDs.

The undersigned is authorized to submit the bid on behalf of *[name of the bidder]* as evidenced by the attached *[state the written authority]*.

We acknowledge that failure to sign each and every page of this Bid Form, including the attached Schedule of Prices, shall be a ground for the rejection of our bid.

Name: \_\_\_\_\_

Legal capacity: \_\_\_\_\_

Signature: \_\_\_\_\_

Duly authorized to sign the Bid for and behalf of: \_\_\_\_\_

Date: \_\_\_\_\_



## **Bid Securing Declaration Form**

*[shall be submitted with the Bid if bidder opts to provide this form of bid security]*

---

REPUBLIC OF THE PHILIPPINES)  
CITY OF \_\_\_\_\_ ) S.S.

### **BID SECURING DECLARATION** **Project Identification No.: *[Insert number]***

To: *[Insert name and address of the Procuring Entity]*

I/We, the undersigned, declare that:

1. I/We understand that, according to your conditions, bids must be supported by a Bid Security, which may be in the form of a Bid Securing Declaration.
2. I/We accept that: (a) I/we will be automatically disqualified from bidding for any procurement contract with any procuring entity for a period of two (2) years upon receipt of your Blacklisting Order; and, (b) I/we will pay the applicable fine provided under Section 6 of the Guidelines on the Use of Bid Securing Declaration, within fifteen (15) days from receipt of the written demand by the procuring entity for the commission of acts resulting to the enforcement of the bid securing declaration under Sections 23.1(b), 34.2, 40.1 and 69.1, except 69.1(f), of the IRR of RA No. 9184; without prejudice to other legal action the government may undertake.
3. I/We understand that this Bid Securing Declaration shall cease to be valid on the following circumstances:
  - a. Upon expiration of the bid validity period, or any extension thereof pursuant to your request;
  - b. I am/we are declared ineligible or post-disqualified upon receipt of your notice to such effect, and (i) I/we failed to timely file a request for reconsideration or (ii) I/we filed a waiver to avail of said right; and
  - c. I am/we are declared the bidder with the Lowest Calculated Responsive Bid, and I/we have furnished the performance security and signed the Contract.

IN WITNESS WHEREOF, I/We have hereunto set my/our hand/s this \_\_\_\_ day of *[month]* *[year]* at *[place of execution]*.

*[Insert NAME OF BIDDER OR ITS AUTHORIZED  
REPRESENTATIVE]*

*[Insert signatory's legal capacity]*

Affiant

**[Jurat]**

*[Format shall be based on the latest Rules on Notarial Practice]*

**Price Schedule for Goods Offered from Within the Philippines**  
*[shall be submitted with the Bid if bidder is offering goods from within the Philippines]*

---

**For Goods Offered from Within the Philippines**

Name of Bidder \_\_\_\_\_ Project ID No. \_\_\_\_\_ Page \_\_\_ of \_\_\_

1	2	3	4	5	6	7	8	9	10
Item	Description	Country of origin	Quantity	Unit price EXW per item	Transportation and all other costs incidental to delivery, per item	Sales and other taxes payable if Contract is awarded, per item	Cost of Incidental Services, if applicable, per item	Total Price, per unit (col 5+6+7+8)	Total Price delivered Final Destination (col 9) x (col 4)

Name: \_\_\_\_\_

Legal Capacity: \_\_\_\_\_

Signature: \_\_\_\_\_

Duly authorized to sign the Bid for and behalf of: \_\_\_\_\_

# *Price Schedule for Goods Offered from Abroad*

*[shall be submitted with the Bid if bidder is offering goods from Abroad]*

---

## *For Goods Offered from Abroad*

Name of Bidder \_\_\_\_\_ Project ID No. \_\_\_\_\_ Page \_\_\_ of \_\_\_

1	2	3	4	5	6	7	8	9
Item	Description	Country of origin	Quantity	Unit price CIF port of entry (specify port) or CIP named place  (specify border point or place of destination)	Total CIF or CIP price per item  (col. 4 x 5)	Unit Price Delivered Duty Unpaid (DDU)	Unit price Delivered Duty Paid (DDP)	Total Price delivered DDP (col 4 x 8)

Name: \_\_\_\_\_

Legal Capacity: \_\_\_\_\_

Signature: \_\_\_\_\_

Duly authorized to sign the Bid for and behalf of: \_\_\_\_\_

